

## eK!



## 18 - 20 - 24



### INSTALLATION AND SERVICING MANUAL





<https://www.unicalag.it/prodotti/caldaie-domestiche-50/condensazione-gas/5665/ek>



**Provisions for proper disposal of the product.**

At the end of its life cycle the product must not be disposed of as urban waste. It can be taken to a special recycling centre managed by the local authorities, or to a dealer who offers this service. Separate disposal of a domestic appliance avoids possible negative consequences for the environment and human health deriving from inappropriate waste handling and allows the recovery of the materials of which it is made, in order to obtain significant energy and resource savings.

Attention: this manual contains instructions for the exclusive use of the professionally qualified installer and/or maintenance technician in compliance with current legislation.  
 The user is NOT qualified to intervene on the boiler.  
 The manufacturer will not be held liable in case of damage to persons, animals or objects resulting from failure to comply with the instructions contained in the manuals supplied with the boiler.

<b>1 GENERAL INFORMATION</b> .....	4
1.1 General warnings .....	4
1.2 Symbols used in the manual .....	5
1.3 Appropriate use of appliance .....	5
1.4 Information for system manager .....	5
1.5 Safety warnings .....	6
1.6 Technical data plate .....	7
1.7 Water treatment .....	8
1.8 Boiler antifreeze protection .....	9

<b>2 TECHNICAL FEATURES AND DIMENSIONS</b> .....	10
2.1 Technical features .....	10
2.2 Main components view and dimensions .....	10
2.3 Available flow rate / pressure diagram .....	12
2.4 Operation data .....	13
2.5 General features .....	13
2.6 Data according to the directive ErP .....	14

<b>3 INSTALLATION INSTRUCTIONS</b> .....	15
3.1 General warnings .....	15
3.2 Installation standards .....	15
3.3 Preventive system verification and adjustment operations .....	15
3.4 Packaging .....	16
3.5 Positioning the boiler .....	17
3.5.1 References and positioning .....	18
3.6 Flue gas exhaust pipe connection .....	20
3.7 Connections .....	27
3.8 Filling the system .....	28
3.9 Electrical connections .....	29
3.10 Commissioning .....	31
3.11 Measurement of combustion efficiency during installation .....	32
3.11.1 Calibration function activation .....	32
3.12 Burner adjustment .....	34
3.12.1 Function activation combustion adjustment .....	36
3.12.2 Adaptation of the power to the heating system .....	40

<b>4 MAINTENANCE INSTRUCTIONS</b> .....	41
4.1 Inspection and maintenance instructions .....	41
4.2 Parameters that can be edited from the control panel .....	43
4.3 Adaptation to the use of other gas .....	44
4.3.1 Calibration AUTO_CAL .....	45
4.4 Important Note .....	47
4.5 Wiring diagram .....	48
4.6 Error codes .....	49
4.6.1 Combustion control alarms .....	50
4.7 Set parameter .....	51

## 1.1 - GENERAL WARNINGS

The instruction booklet is an integral and essential part of the product and must be kept by the user.

Read the warnings contained in this instruction booklet carefully as they provide important guidelines regarding installation, use and maintenance safety.

Keep the booklet with care for further consultation.

**Installation and maintenance must be performed in compliance with the standards in force according to the instructions of the manufacturer, up to standard and by personnel qualified and certified in compliance with law.**

**Systems for the production of domestic hot water MUST be constructed entirely with compliant materials.**

**By professionally qualified personnel we mean: personnel with specific technical skill in the field of heating system components for civil use, domestic hot water production and maintenance. Personnel must have the qualifications provided for by current legislation.**

Incorrect installation or improper maintenance can cause damage to persons, animals or objects for which the manufacturer is not responsible.

Before performing any cleaning or maintenance, disconnect the appliance from the energy mains by acting on the switch of the system and/or through the specific cut-off devices.

Do not obstruct the terminals of the intake/exhaust ducts.

In case of failure and/or malfunctioning of the appliance, switch it off and do not try to repair it or intervene on it directly. Contact only personnel qualified in compliance with law.

Any repairs must be performed solely by personnel authorised by Unical AG S.p.A., using original spare parts only. Failure to comply with the above can compromise the safety of the appliance and void the warranty.

To guarantee appliance efficiency and its correct operation, yearly maintenance must be performed by qualified personnel.

Should you decide not to use the appliance, parts entailing potential sources of hazard must be made safe.

Before commissioning an appliance that has not been used, wash the domestic hot water production system, making the water flow until it has been fully replaced.

Should the appliance be sold or transferred to a new owner or if you move and leave the appliance, always make sure that the instruction booklet accompanies it in order to be consulted by the new owner and/or installer.

Only original accessories must be used for all appliances with optionals or kits (including electric).

This appliance is intended solely for the use for which it was expressly designed.

Any other use is to be considered improper and therefore dangerous (\*).

## 1.2 - SYMBOLS USED IN THE MANUAL

Pay special attention when reading this manual to the parts marked by the symbols:



**DANGER!**  
Serious danger  
to safety  
and health



**ATTENTION!**  
Possible dangerous  
situation for the product  
and the environment



**NOTE!**  
Tips  
for the user



**NOTE!**  
For further details  
refer to the Technical  
Information:  
at the web address  
indicated  
on page 2



**DANGER!**  
Danger of burns!



**OBLIGATION!**  
wear gloves  
protective

## 1.3 - APPROPRIATE USE OF APPLIANCE



The boiler has been built according to the current level of engineering and acknowledged technical safety rules.

Nonetheless, if improperly used, dangers could arise for the safety and life of the user and other persons or damage to the equipment or other objects.

The appliance is designed to work in heating systems, with hot water circulation, for the production of domestic hot water.

Any other use is considered improper.

For any damage resulting from improper use UNICAL AG. S.p.A. assumes no responsibility.

Use according to the intended purposes also includes strict compliance with the instructions in this manual.

## 1.4 - INFORMATION PROVIDED TO THE USER



The user must be instructed concerning the use and operation of his heating system, in particular:

- Deliver these instructions to the user, as well as other documents concerning the appliance inserted in the envelope inside the packaging. **The user must keep this documentation safe for future consultation.**
- Inform the user about the importance of the air vents and the flue gas exhaust system, highlighting their essential features and the absolute prohibition of modifying them.
- Inform the user concerning controlling the system's water pressure as well as operations to restore it.
- Inform the user concerning correct temperature control, control units/thermostats and radiators for saving energy.
- Please note that, in compliance with the standards in force, the inspection and maintenance of the appliance must be carried out in compliance with the regulations and frequency indicated by the manufacturer.
- Should the appliance be sold or transferred to a new owner or if you move and leave the appliance, always make sure that the instruction booklet accompanies it in order to be consulted by the new owner and/or installer.

**The manufacturer will not be held liable in the event of damage to persons, animals or objects resulting from failure to comply with the instructions contained in this manual.**

## 1.5 - SAFETY WARNINGS



### **ATTENTION!**

The boiler cannot be used by children.

The boiler can be used by adults and only after having carefully read the user's manual. Children should be supervised to ensure that they do not play or tamper with the device.



### **ATTENTION!**

The appliance must be installed, adjusted and maintained by professionally qualified personnel, in compliance with the standards and provisions in force. Incorrect installation can cause damage to persons, animals and objects for which the manufacturer cannot be held responsible.



### **DANGER!**

**NEVER** attempt performing maintenance or repairs on the boiler on your own initiative. Any work must be done by professionally qualified personnel. We recommend stipulating a maintenance contract.

Insufficient or irregular maintenance can jeopardise the operating safety of the appliance and cause damage to persons, animals and objects for which the manufacturer cannot be held responsible.



**Changes to the parts connected to the appliance (once the appliance installation is complete)**

Do not modify the following parts:

- the boiler
- the gas, air, water and electricity supply lines
- the flue gas pipe, the safety valve and the exhaust pipe
- the construction parts which affect the operating safety of the appliance



### **Attention!**

To tighten or loosen the screwed fittings, use only appropriate fixed spanners.

Incompliant use and/or inappropriate tools can cause damage (e.g. water or gas leakage).



### **ATTENTION!**

#### **Indications for propane gas-fired appliances**

Make sure that the gas tank has been deaerated before installing the appliance.

For state-of-the-art tank venting, contact the LPG supplier or person qualified in compliance with the law requirement.

If the tank has not been professionally deaerated, ignition problems could arise.

In that case, contact the supplier of the LPG tank.



### **Smell of gas**

Should a smell of gas be perceived, follow these safety guidelines:

- do not turn electric switches on or off
- do not smoke
- do not use the telephone
- close the gas shut-off valve
- air out the area where the gas leakage has occurred
- inform the gas supplier or a company specialised in installation and maintenance of heating systems.



### **Explosive and easily flammable substances**

Do not use or store explosive or easily flammable materials (e.g. petrol, paints, paper) in the room where the appliance is installed.



### **DANGER!**

Do not use the appliance as a supporting base for objects.

In particular, do not place receptacles containing liquids (Bottles, Glasses, Jars or Detergents) on top of the appliance.

If the appliance is installed inside a housing, do not insert or rest other objects inside this housing.

# 1.6 - TECHNICAL DATA PLATE

## The CE marking

certifies the compliance of the equipment with the essential safety requirements defined in the directives and applicable European regulations and that its functioning satisfy applicable technical standards.

The CE marking is affixed to each piece of equipment with an appropriate label.

The CE declaration of conformity issued in accordance with international standards by the manufacturer, is placed in documentation envelope supplied with the product.



**The technical data plate is located outside the boiler on the lower right side.**

### KEY:

- 1 = CE monitoring body
- 2 = Type of boiler
- 3 = Boiler model
- 4 = Number of stars (directive 92/42 EEC)
- 5 = (S.N°) Serial Number
- 6 = P.I.N. Product Identification Number
- 7 = Types of approved flue gas exhaust configurations
- 8 = (NOx) NOx Class

- A = Heating circuit characteristics
- 9 = (Pn) Effective nominal output
- 10 = (Pcond) Effective output in condensation
- 11 = (Qn) Maximum heat output
- 12 = (Adjusted Qn) Adjusted for rated heat output
- 13 = (PMS) Max. heating operating pressure
- 14 = (T max) Max. heating temperature

- B = Domestic hot water circuit characteristics
- 15 = (Qnw) Rated heat output in domestic hot water function (if different to Qn)
- 16 = (D) Specific D.H.W. flow rate according to EN 625 - EN 13203-1
- 19 = (PMW) Max. domestic hot water operating pressure
- 20 = (T max) Max. domestic hot water temperature

- C = Electrical characteristics
- 21 = Electrical power supply
- 22 = Consumption
- 23 = Protection rating

- D = Countries of destination
- 24 = Direct and indirect countries of destination
- 25 = Gas category
- 26 = Supply pressure

- E = Factory settings
- 27 = Adjusted for gas type X
- 28 = Space for national brands

- G = ErP
- 29 = Seasonal space heating energy efficiency
- 30 = Energy efficiency in DHW production mode

(2)	
Model	(3)
S.N°	(5) /      PIN (6)
Types	(7)      NOx (8)
 Central Heating	Pn (9) kW      Pcond (10) kW
	Qn (11) kW      Adjusted Qn (12) kW
	PMS (13) bar      T max (14) °C
	(A)
 DHW	Qnw (15) kW      D (16) l/min
	PMW (19) bar      T max (20) °C
(B)	
(G)      s (29) %      wh (30) %	
(E) Factory setting <input checked="" type="checkbox"/> MET GPL	
	(27) mbar <input type="checkbox"/>
	mbar <input type="checkbox"/>
	mbar <input type="checkbox"/>
	mbar <input type="checkbox"/>
	mbar <input type="checkbox"/>
	mbar <input type="checkbox"/>
	mbar <input type="checkbox"/>
	mbar <input type="checkbox"/>
(C) Electrical Power supply	
(21) V      HZ      (22) W	
IP class:      (23)	
(D) Countries of destination	
(24)	(25)
(26)	
(1)	
 <div style="border: 1px dashed black; display: inline-block; padding: 2px;">(28)</div>	
Made in Italy	

## 1.7 - WATER TREATMENT



The treatment of the supply water allows to prevent inconveniences and maintain the functionality and efficiency of the generator over time.



The ideal water pH in heating systems must be within:

VALUE	MIN	MAX
PH	6.5	8
Hardness [°fr]	9	15



To minimise corrosion, it is crucial to use a corrosion inhibitor; in order for it to work properly, the metal surfaces must be clean.

(see system protection ACCESSORIES sect. in domestic price list)

### ATTENTION!

**ANY DAMAGE TO THE BOILER CAUSED BY THE FORMATION OF FOULING OR BY CORROSIVE WATER WILL NOT BE COVERED BY THE WARRANTY.**

ATTENTION (\*) see general warnings 1.1

The heating only models are NOT suitable for the production of water for human consumption according to Ministerial Decree D.M. 174/2004.

### NOTE!

Further details in the section “Technical Information” on the boiler page of the [www.unicalag.it](http://www.unicalag.it) website



For outdoor installations, in partially protected places, it is necessary to use the additional resistance kit (optional) for the anti-freeze protection of the DHW and siphon fittings.

Declared room temperature, with use of the resistance kit = -15 ° C.



## 1.8 - BOILER ANTIFREEZE PROTECTION

To activate the antifreeze function only, position the two knobs as shown in the figure.

The Antifreeze protection is always active. Even by disabling the heating and domestic hot water services.

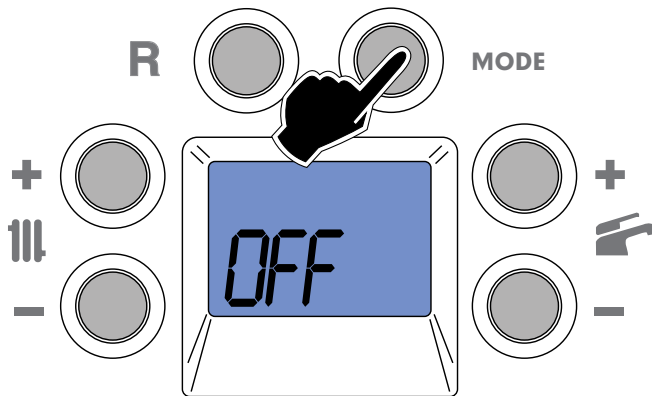

This protection can intervene only if the electricity and gas supplies are connected.

If one of the two is not available and upon reset (SMG - flow sensor general) a temperature of  $< 5^{\circ}\text{C}$  is detected, the appliance will behave as described in tab. pos 2.



The heating system can be protected effectively from frost by using antifreeze products with inhibitor for heating systems (specific for multidmetal)

Do not use car engine antifreeze products as they could damage the water gaskets.



If the function is activated automatically, CH symbol will flash on the display. If antifreeze request is not completed in 20 min. the function is suspended for 40 min. subsequent.

POS	ANTIFREEZE FUNCTION				
	Power supplies		SMG (*)	Status function antifreeze	Actions
	Electric	Gas			
1	ON	ON	$< 5^{\circ}\text{C}$	ON	- Burner and Pump ON until $T > 35^{\circ}\text{C}$ (**)
2	ON	OFF	$< 5^{\circ}\text{C}$	ON	- Pump ON till $T > 35^{\circ}\text{C}$
	OFF	ON		OFF	- Burner and Pump OFF
	OFF	OFF		OFF	- Burner and Pump OFF
(*) Sensor 11 par. 2.2					
(**) Burner active at minimum power					

# 2

## TECHNICAL FEATURES AND DIMENSIONS

**NOTE!**

For further details refer to the Technical Information from the website (link at page 2)

### 2.1 - TECHNICAL FEATURES

### 2.2 - VIEW WITH THE INDICATION OF THE MAIN COMPONENTS AND DIMENSIONS

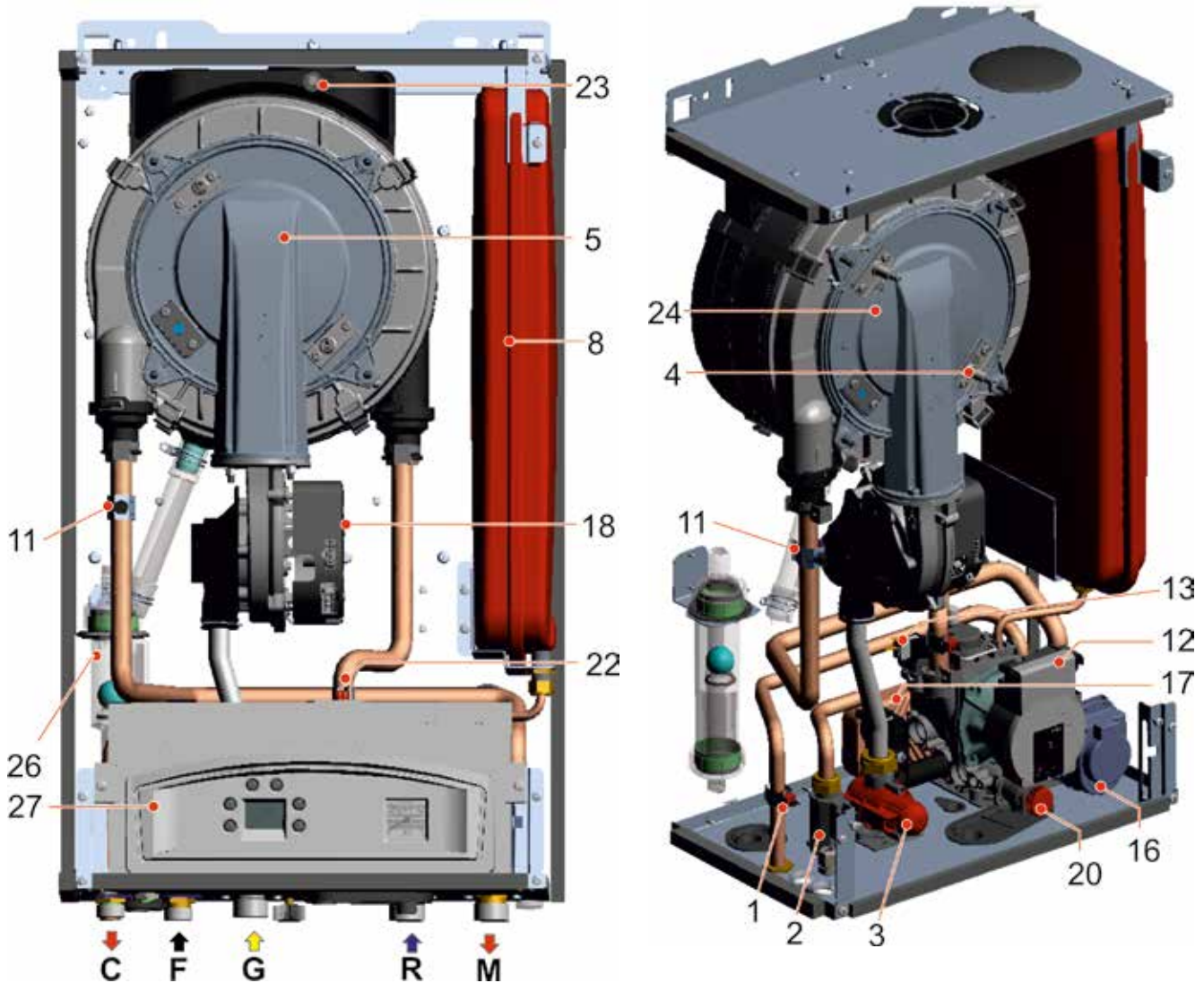

KEY		
N°	S.E.	Description
1	SS	Domestic hot water temperature sensor
2	FLS	Flow switch with cold water filter
3	VG	Gas valve
4	E.ACC /RIL	Ignition/detection electrode
5		Burner
8		Expansion vessel
10	TL	Safety thermostat
11	SRM (1 - 2)	Heating temperature sensor

12	P	Pump
13	DK	Water deficiency pressure switch
16		Diverting valve
17		Plate heat exchanger
18	VM	Fan
20		Safety valve
22	SRR	Return temperature sensor
23	TLC	Flue gas collector safety thermostat
24		Aluminium Heat Exchanger/Capacitor
26		Condensate drain siphon

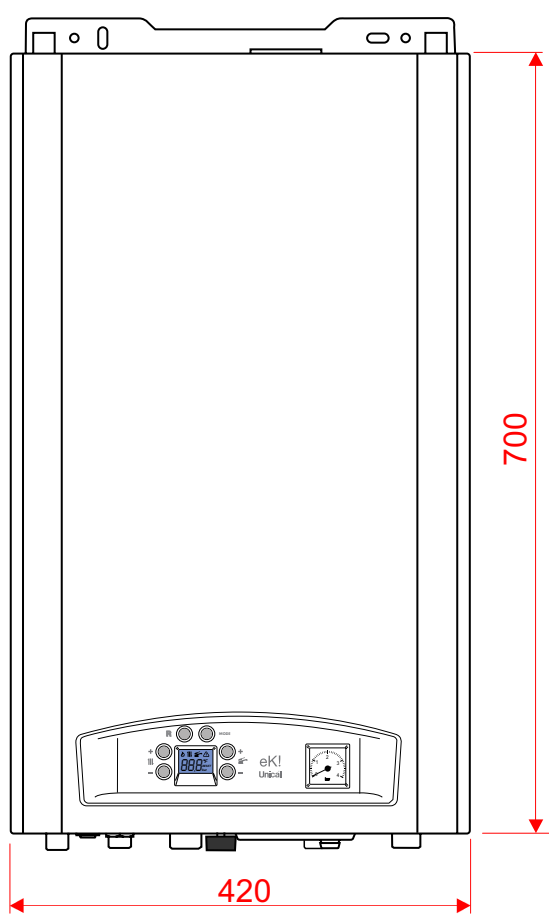

View from above

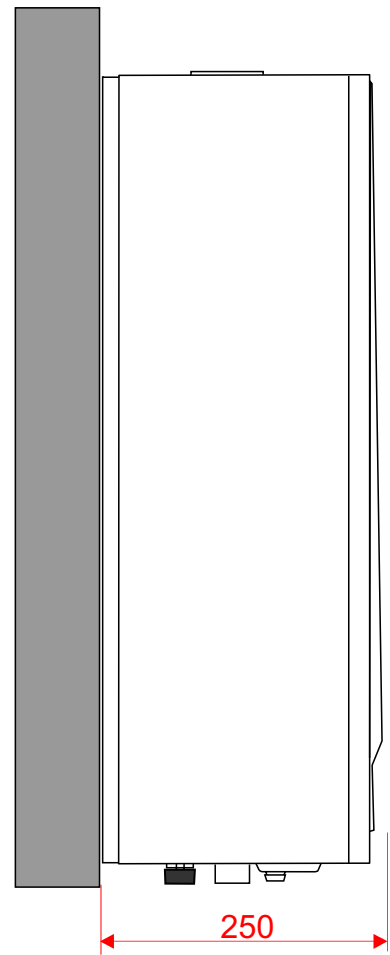

View from below

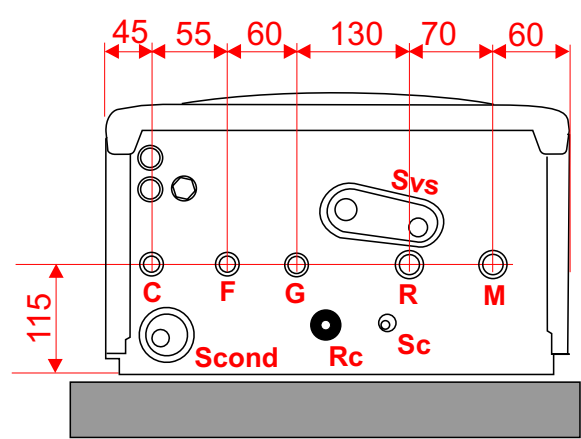
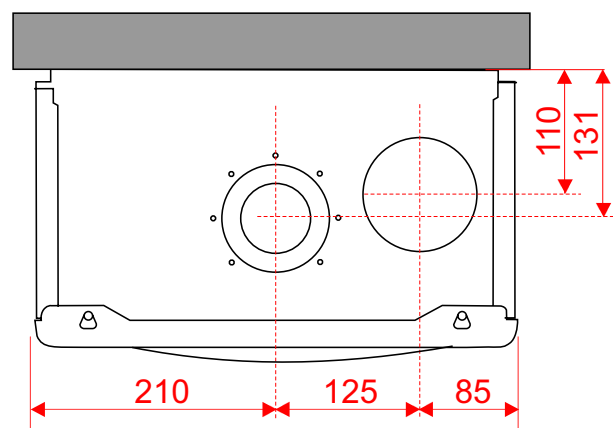

27		Control panel	
C		Domestic hot water outlet	G 1/2
G		Gas inlet	G 3/4
F		Cold water inlet	G 1/2
M		Heating system flow	G 3/4
R		Heating system return	G 3/4
Rc		Filling valve (only EU market)	
Sc		Boiler drain	

Svs		Safety valve drain
Sccond		Condensation drain
	S.E.	= WIRING DIAGRAM KEY see par. 4.5

### 2.3 - DIAGRAM OF FLOW RATE/PRESSURE AVAILABLE FOR INSTALLATION

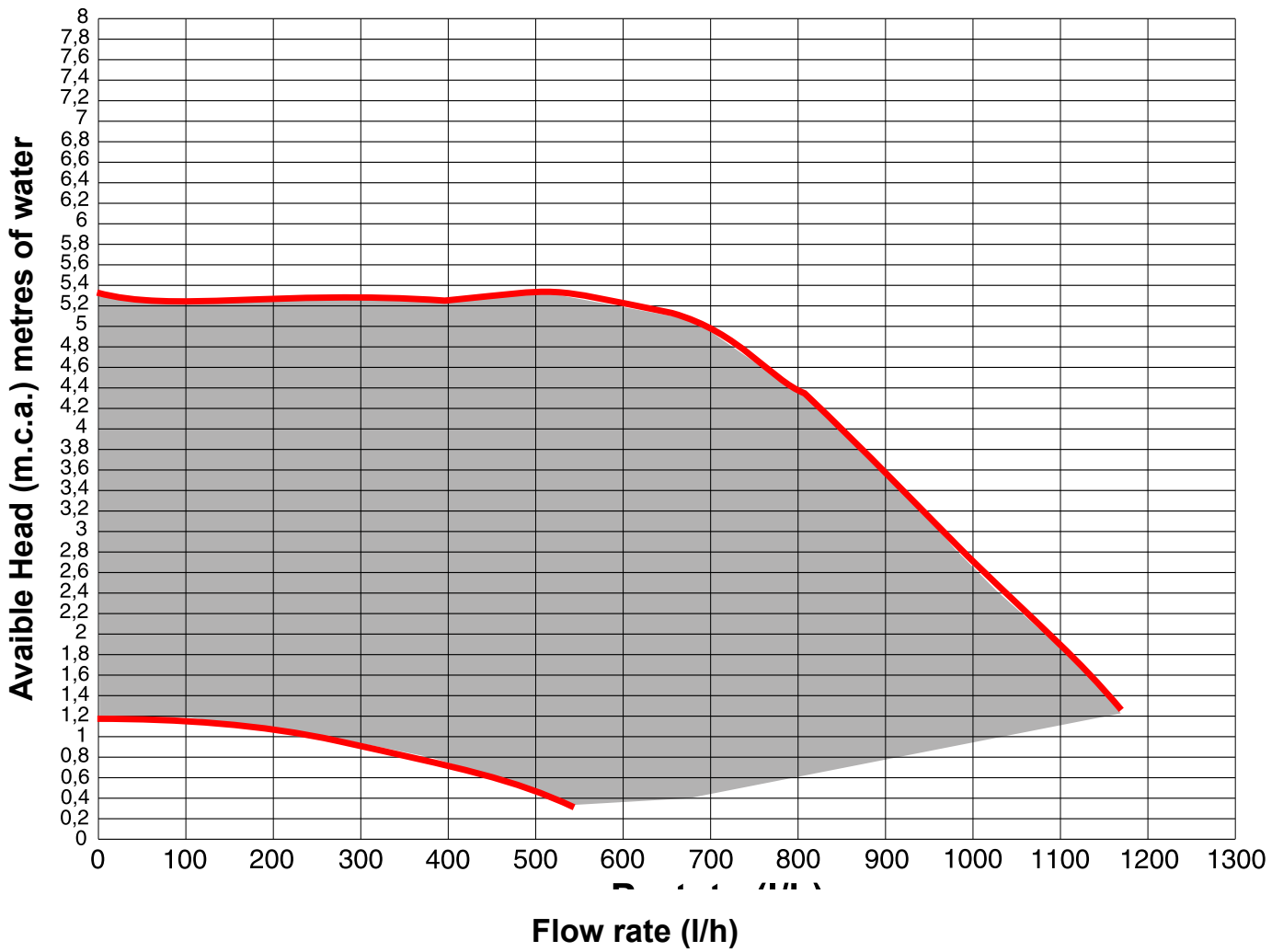

## 2.4 - OPERATING DATA

For the adjustment data: NOZZLES - PRESSURES - DIAPHRAGMS - FLOW RATES refer to the paragraph ADAPTATION FOR USE WITH OTHER GASES



 Our appliances are built to work with natural gas (G20), G.P.L. and mixtures of methane and hydrogen up to 20% by volume (20% H2NG). The supply pipe must be equal to or greater than the fitting of the appliance.

		eK! R 18-C 18	eK! R 20-C 20	eK! R 24-C 24
Nominal heat input in CH / DHW mode (***)	kW	18 / 24	20 / 24	24 / 24
Minimum heat input with Nat. Gas / Propane	kW	3,0 / 4,6	3,0 / 4,6	3,0 / 4,6
Nominal heat input on L.V.C. Qn <b>with gas 20%H2NG</b>	kW	16,9	18,8	22,6
Minimum heat input on L.V.C. Qmin <b>with gas 20%H2NG</b>	kW	3,7	3,7	3,7
Nominal heat input DHW <b>with gas 20%H2NG</b>	kW	22,6	22,6	22,6
Nominal heat output / DHW (***)	kW	17,5 / 23,6	19,4 / 23,6	23,3 / 23,6
Minimum heat output / DHW (***)	kW	2,8 / 2,8	2,8 / 2,8	2,8 / 2,8
Nominal output in condensation 50/30	kW	19,1	21,2	25,5
Minimum heat output in condensation 50/30	kW	3,1	3,1	3,1
Combustion efficiency at full load	%	97,7	97,3	97,4
Combustion efficiency at part load	%	97,3	97,3	97,3
Heat losses through the casing (min.-max.)	%	3 - 0,5	2,9 - 0,1	3 - 0,2
(*) Net flue gas temperature $t_f - t_a$ (max.)	°C	46,4	52,9	52,5
Flue gas mass flow rate (min.-max)	g/s	1,4 - 8,3	1,4 - 9,2	1,4 - 11
Air excess $\lambda$	%	26,8	26,8	26,8
CO <sub>2</sub>	%	9,0 - 9,0	9,0 - 9,0	9,0 - 9,0
CO at 0% of O <sub>2</sub> (min. - max)	ppm	17 - 122	17 - 142	17 - 170
Maximum production of condensate	kg/h	2,9	3,2	3,9
Chimney heat losses with burner ON (min. - max.)	%	2,7 - 2,3	2,7 - 2,7	2,7 - 2,7
Chimney heat losses with burner OFF	%	0,3	0,3	0,2
Head available at the base of the chimney min. / max.	Pa	2 / 130	2 / 130	2 / 130
(**) Sound pressure level LpA at nominal operation	dB(A)	40	40	41
(**) Sound pressure level LpA at medium operation	dB(A)	39	40	39
Notes: (*) Room Temperature = 20°C Data obtained with appliance operated with Nat Gas (G20)				
Note: (**) measured in free field at 1 m distance from the device				
Note: (***) DHW production power for domestic hot water only for C models (combined boilers)				

## 2.5 - GENERAL FEATURES

		eK!					
		R18	C18	R20	C20	R24	C24
Appliance category		II <sub>2H3P</sub>		II <sub>2H3P</sub>		II <sub>2H3P</sub>	
Minimum heat. circuit output ( $\Delta t$ 20 °C)	l/min	2,0		2,0		2,0	
Minimum heating circuit pressure	bar	0,5		0,5		0,5	
Maximum heating circuit pressure	bar	3		3		3	
Primary circuit content	l	2,3		2,3		2,3	
Maximum operating temperature in heat.	°C	85		85		85	
Minimum operating temperature in heat.	°C	30		30		30	
Expansion vessel total capacity	l	6		6		6	
Expansion vessel pre-load	bar	1		1		1	
Maximum system capacity (max temp. calc.)	l	128		128		128	
Minimum domestic hot water circuit flow rate	l/min.	-	2,0	-	2,0	-	2,0
Minimum domestic hot water circuit pressure	bar	-	0,9	-	0,9	-	0,9
Maximum domestic hot water circuit pressure	bar	-	6	-	6	-	6
Domestic hot water specific flow rate ( $\Delta t$ 30 °C) "D"	l/min.	-	10,8	-	10,8	-	10,8
Production of D.H.W. in continuous operation with $\Delta t$ 45 K	l/min.	-	7,3	-	7,3	-	7,3
Production of D.H.W. in continuous operation with $\Delta t$ 40 K	l/min.	-	8,2	-	8,2	-	8,2
Production of D.H.W. in continuous operation with $\Delta t$ 35 K	l/min.	-	9,3	-	9,3	-	9,3
Production of D.H.W. in continuous operation with $\Delta t$ 30 K	l/min.	-	10,9	-	10,9	-	10,9
Production of D.H.W. in continuous operation with $\Delta t$ 25 K (*)	l/min.	-	13,1	-	13,1	-	13,1
Adjustable DHW temperature	°C	-	35-60	-	35-60	-	35-60
Voltage/Frequency electric power supply	V-Hz	230/50		230/50		230/50	
Fuse on the power supply	A (F)	3,15		3,15		3,15	
Power consumption max	kW	0,081	0,081	0,081	0,081	0,081	0,081
Protection rating	IP	X5D		X5D		X5D	
Net weight	kg		28		28		28
Gross weight	kg		30,5		30,5		30,5
<b>F Factor</b>		-	2	-	2	-	2
<b>R Factor</b>		-	III	-	III	-	III
(*) mixed							

## 2.6 - DATA ACCORDING TO ErP DIRECTIVE

Description	Symbol	Unit	Eki					
			R 18	C 18	R20	C20	R24	C24
Nominal Heat Output	P <sub>nominal</sub>	kW	17		19		23	
Seasonal space heating energy efficiency	$\eta_s$	%	92		92		92	
<b>Seasonal efficiency class in heating mode</b>			<b>A</b>		<b>A</b>		<b>A</b>	
<b>For CH only and combination boilers: useful heat output</b>								
Useful Heat Output in high-temperature regime (Tr 60 °C / Tm 80 °C)	P <sub>4</sub>	kW	17,5		19,4		23,3	
Useful efficiency at nom. heat output in high-temperature regime (Tr 60 °C / Tm 80 °C)	$\eta_4$	%	87,5		87,5		87,4	
Useful heat output at 30% of nom. heat output in low-temperature regime (Tr 30 °C)	P <sub>1</sub>	kW	5,8		6,5		7,8	
Useful efficiency at 30% of nom. heat output in low-temperature regime (Tr 30 °C)	$\eta_1$	%	97,2		97,3		97,4	
Range-rated boiler: YES / NO			NO		NO		NO	
<b>Auxiliary electricity consumption</b>								
At full load	el <sub>max</sub>	kW	0,030		0,034		0,040	
At part load	el <sub>min</sub>	kW	0,012		0,012		0,012	
In stand-by mode	P <sub>SB</sub>	kW	0,005		0,005		0,005	
<b>Other items</b>								
Heat loss in stand-by	P <sub>stb</sub>	kW	0,058		0,058		0,058	
Emissions of nitrogen oxides ref. PCS	NO <sub>x</sub>	mg/kWh	32		29		33	
NO <sub>x</sub> Class			6		6		6	
Annual electricity consumption	Q <sub>HE</sub>	GJ	55		61		73	
Inside sound power level	L <sub>wa</sub>	dB (A)	45		46		47	
<b>For CH &amp; DHW production boilers</b>								
Declared load profile			-	<b>XL</b>	-	<b>XL</b>	-	<b>XL</b>
Energy efficiency in DHW production mode	$\eta_{wh}$	%	-	83	-	83	-	83
Daily electricity consumption	Q <sub>elec</sub>	kWh	-	0,18	-	0,18	-	0,18
Daily fuel consumption	Q <sub>fuel</sub>	kWh	-	23,58	-	23,58	-	23,58
Annual electricity consumption	AEC	kWh	-	40,9	-	40,9	-	40,9
Annual fuel consumption	AFC	GJ	-	17,8	-	17,8	-	17,8
<b>Seasonal efficiency class in DHW production mode</b>			-	<b>A</b>	-	<b>A</b>	-	<b>A</b>

## 3.1 - GENERAL WARNINGS



### ATTENTION!

This boiler is intended solely for the use for which it was expressly designed. Any other use is to be considered improper and therefore dangerous.

This boiler heats water at a temperature lower than the atmospheric pressure boiling temperature.

Before connecting the boiler, have professionally qualified personnel:



a) **Thoroughly wash all the piping of the system to remove any residues or impurities which could jeopardise proper operation of the boiler, even from a hygienic point of view.**

b) Check that boiler is set up to operate with the available type of fuel. This can be seen written on the package and on the technical feature plate;

c) Check that the chimney/flue has an appropriate draught, without any bottlenecks, and that no exhausts from other appliances are inserted, unless the flue has been implemented to accommodate several utilities according to specific standards and regulations in force. Only after this check can the fitting between the boiler and chimney/flue be mounted;



### ATTENTION!

If there is dust and/or if there are aggressive/corrosive vapours present in the installation room, the appliance must be protected suitably and must be able to operate independently from the air in the room.



### ATTENTION!

Only mount the appliance on a closed wall, made of non-flammable material, flat, vertical so that the minimum distances required for installation and maintenance can be observed.



The boiler must be connected to a central heating system and/or domestic hot water supply network compatible with its efficiency and output.



The boiler can be installed outside in a partially protected place or in any case in a place where the boiler is not exposed to the direct action of atmospheric agents.

### NOTE!

Further details in the section "Technical Information" at the address indicated on page 2.

## 3.2 - INSTALLATION STANDARDS

It must be installed by a professionally qualified technician, who shall take the responsibility of observing all local and/or national laws published in the official journal, as well as the applicable technical standards.

### NOTE!

For further details relating to the standards, rules and regulations for safe installation of the thermal unit, refer to the section "Technical Information" on the boiler page of the [www.unicalag.it](http://www.unicalag.it) website

## 3.3 - PREVENTIVE VERIFICATION AND VERIFICATION AND ADJUSTMENT OPERATIONS

### NOTE!

Further details in the section "Technical Information" at the address indicated on page 2.

### 3.4 - PACKAGING

The boiler is supplied completely assembled in a sturdy cardboard box.



After having removed the appliance from the packaging, make sure that the supply is complete and undamaged.



The packaging elements (cardboard box, straps, plastic bags, etc.) **must be kept out of the reach of children as they are potential sources of danger.** Unical AG S.p.A. will not be held liable for damage to persons, animals or objects due to failure to comply with the instruction above.



**OBLIGATION!**  
wear protective gloves

- The boilers must always be lifted and carried by two people, or a carrier carriage or special transport equipment must be used.

As well as the appliance, the packaging contains:

**A DOCUMENTATION ENVELOPE**

- User operating instructions booklet
- Instruction booklet for the installer and maintenance

**Siphon**, (with corrugated tube and fixing strap) inside the boiler.

1

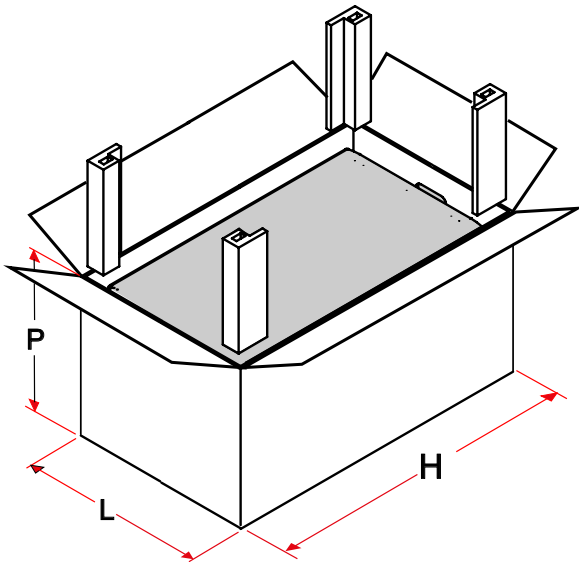

2

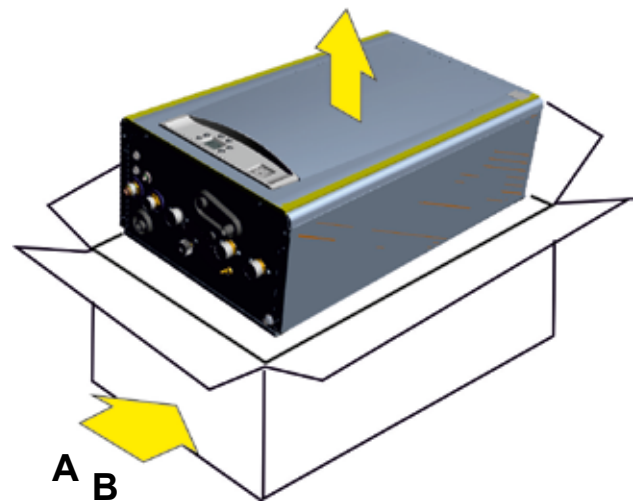

P depth	L width	H height
290 mm	470 mm	810 mm



### 3.5 - POSITIONING THE BOILER

When choosing the place of the installation of the appliance, follow the safety instructions below:

- Place the appliance in rooms protected from frost.
- Avoid installation in rooms with a corrosive or very dusty atmosphere.
- The appliance must only be installed on a vertical and solid wall which can support its weight.
- The wall must not be made of flammable material.

Since the temperature of the wall on which the boiler is installed and the temperature of the coaxial exhaust pipe do not exceed, in normal operating conditions, a room temperature beyond 60 K, it is not necessary to observe the minimum distances from flammable walls.

For boilers with double intake and exhaust pipes, in the event of crossing flammable walls, insert insulation between the wall and the flue gas exhaust pipe.

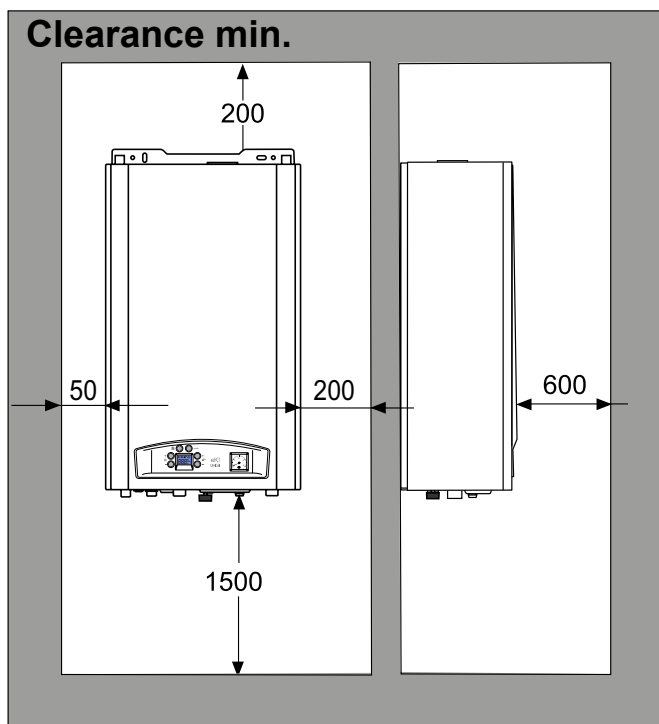

### 3.5.1 - REFERENCES FOR BOILER POSITIONING

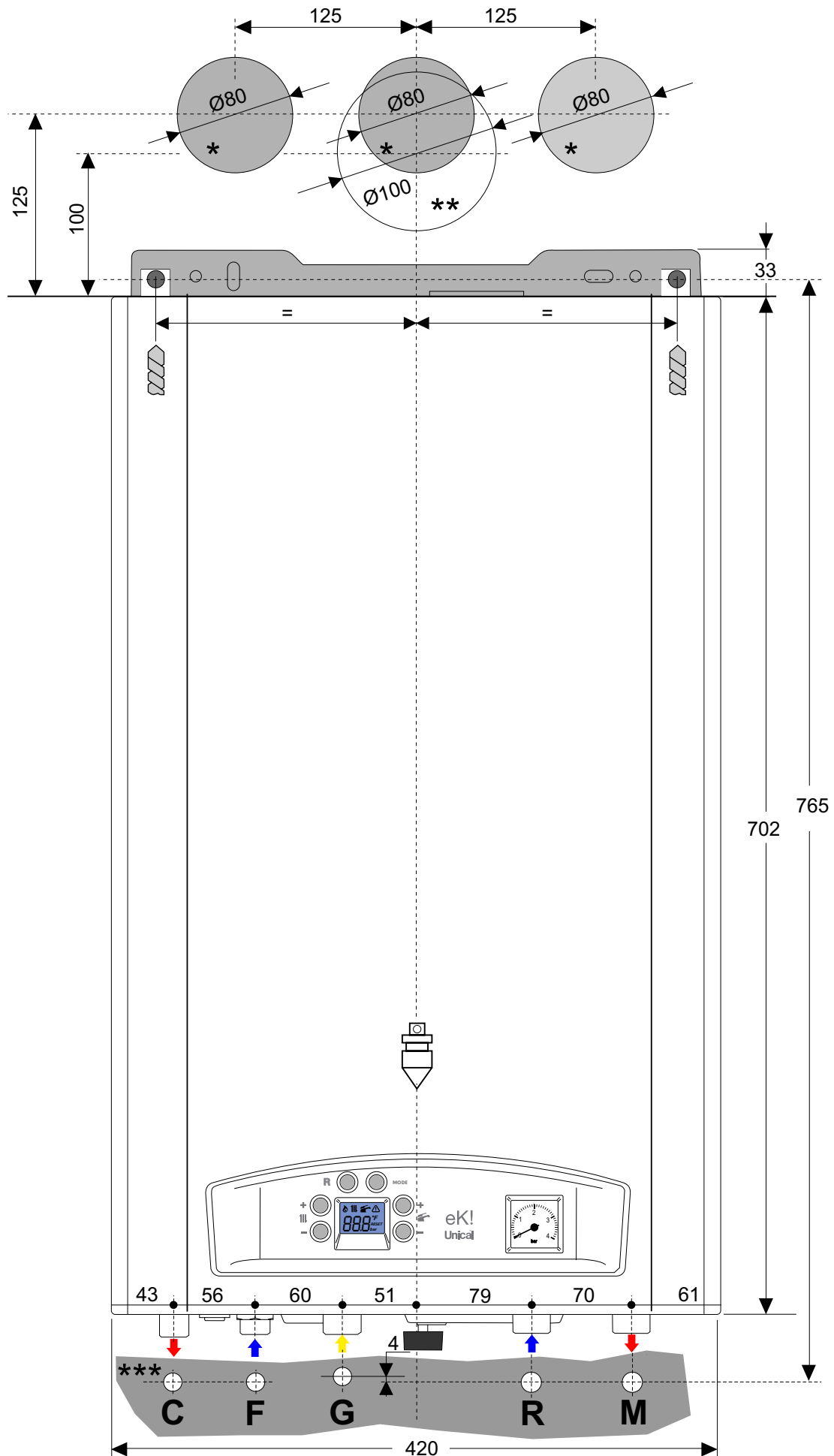

\*\* references for rear outputs coaxial, (kit a)



\*\* references for rear outputs coaxial, with socket and bend

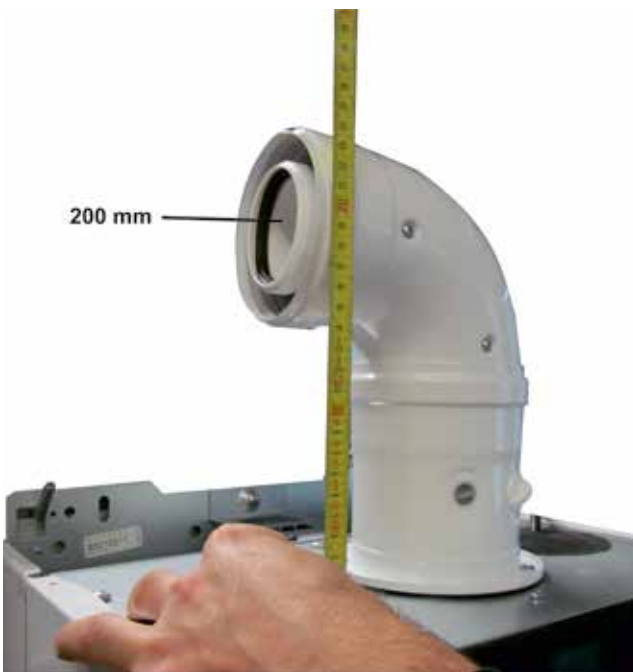

\* references for twin output Ø 80.

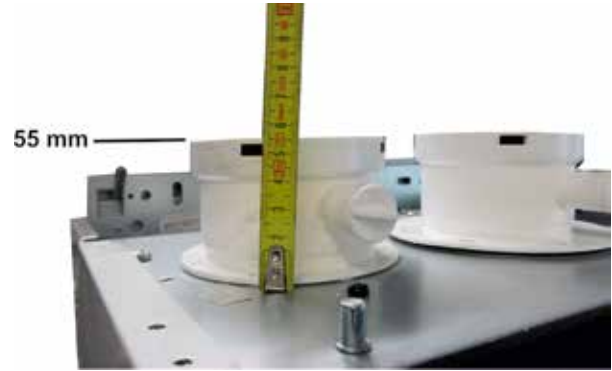

\* references for twin outputs Ø 80 (kit b)

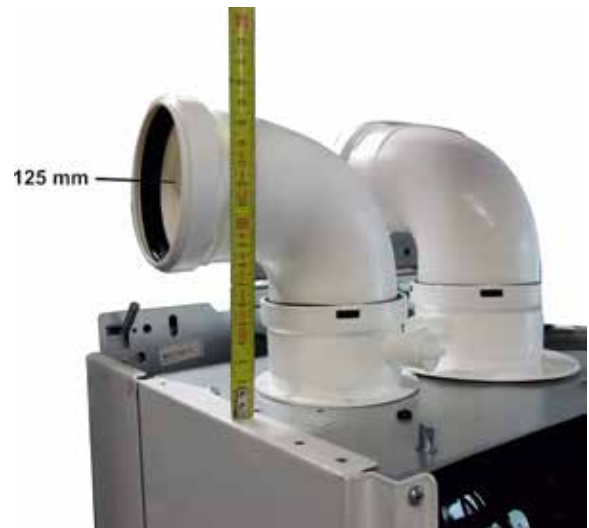

distance from safety relief valve wall / condensate drain

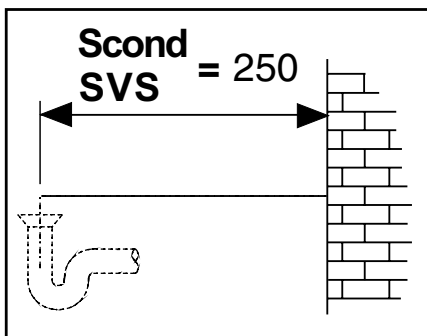

\*\*\* hydraulic outlets reference for installation with horizontal pipe kit 00362527

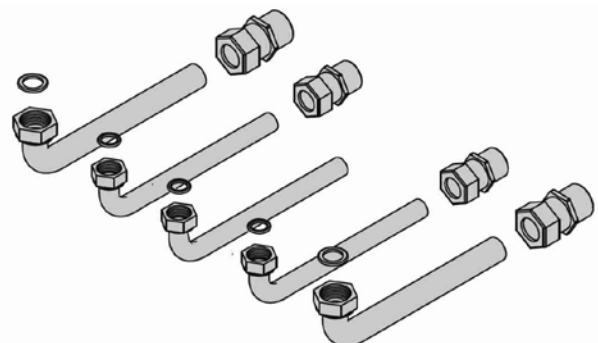

### 3.6 - FLUE GAS EXHAUST PIPE CONNECTION

#### FOR BOILERS WITH FORCED DRAUGHT)

To connect the flue gas exhaust pipe, local and national standards must be observed

**In the event the boiler is replaced, ALWAYS replace the flue gas pipe as well.**

The boiler is type approved for the exhaust configurations listed below:

(\* ) Values in the **MT018** available on the website.



Please note: these values relate to exhausts/made by means of rigid pipes and smooth original UNICAL.



#### ATTENTION

[m] = equivalent meters

(\* ) Values in the **MT018** available on the website (technical info section)

#### Calculation to determine the lengths of the exhaust configurations



#### CAUTION

**LT\*\*** total length is a reference value for the dimensioning of the ducts of **A** (intake) and **S** (Exhaust).

Subtracting the values of **LT** reported, at values of bends\* / terminals\* / extensions\* you get the value:

**if > 0 = OK**

POSSIBLE configuration

**if < 0 = NO**

WRONG configuration

C (13) x		C (13)	
% Slope towards inlet = 3%			
LT** (TOTAL LENGTH or LA intake + L Exhaust)			
COAXIAL Ø60/100		DOUBLE Ø80	
FROM [m]	TO [m]	FROM [m]	TO [m]
1	7	1 + 1	60 (30A+30S)
COAXIAL Ø80/125		DOUBLE Ø60	
FROM [m]	TO [m]	FROM [m]	TO [m]
1	12	1 + 1	30 (10A+20S)
		Distance between air inlet pipe and flue gas exhaust pipe: min 250 mm - max 500	
<b>Horizontal</b> exhaust and intake terminals directed outside via coaxial or double pipes..			

C (33) x		C (33)	
LT** (TOTAL LENGTH or LA intake + L Exhaust)			
COAXIAL Ø60/100		DOUBLE Ø80	
FROM [m]	TO [m]	FROM [m]	TO [m]
1	8,5	0,5 + 0,5	65 (30A+35S)
COAXIAL Ø80/125		DOUBLE Ø60	
FROM [m]	TO [m]	FROM [m]	TO [m]
1	14	1 + 1	30 (10A+20S)
<b>Vertical</b> exhaust and intake terminals directed outside via coaxial or double pipes.			

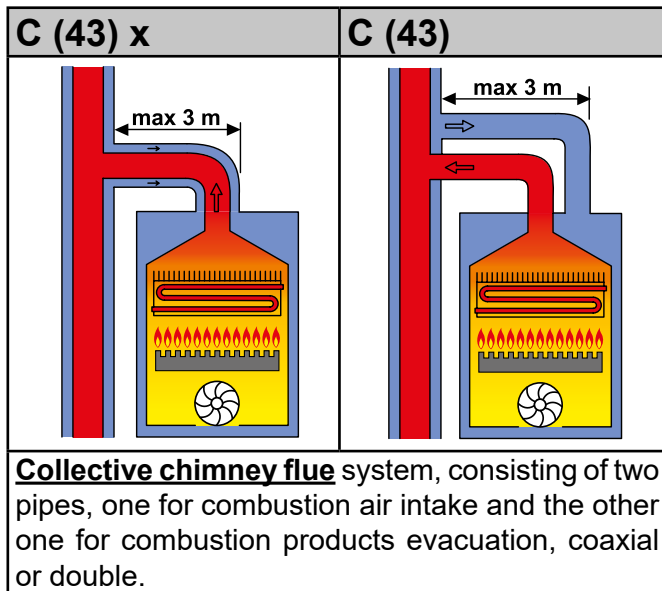

 **Note:**  
for use in **C10** configuration with optional clapét (only for natural gas G20).

It is possible to install the appliance with the “clapét” accessory not supplied by Unical outside the boiler.

The use of the clapét as an accessory requires a dedicated set of parameters to compensate for the pressure drop introduced.

 **Note:** Parameters are released from the after-sales service on request of the installer / technical area site reserved.

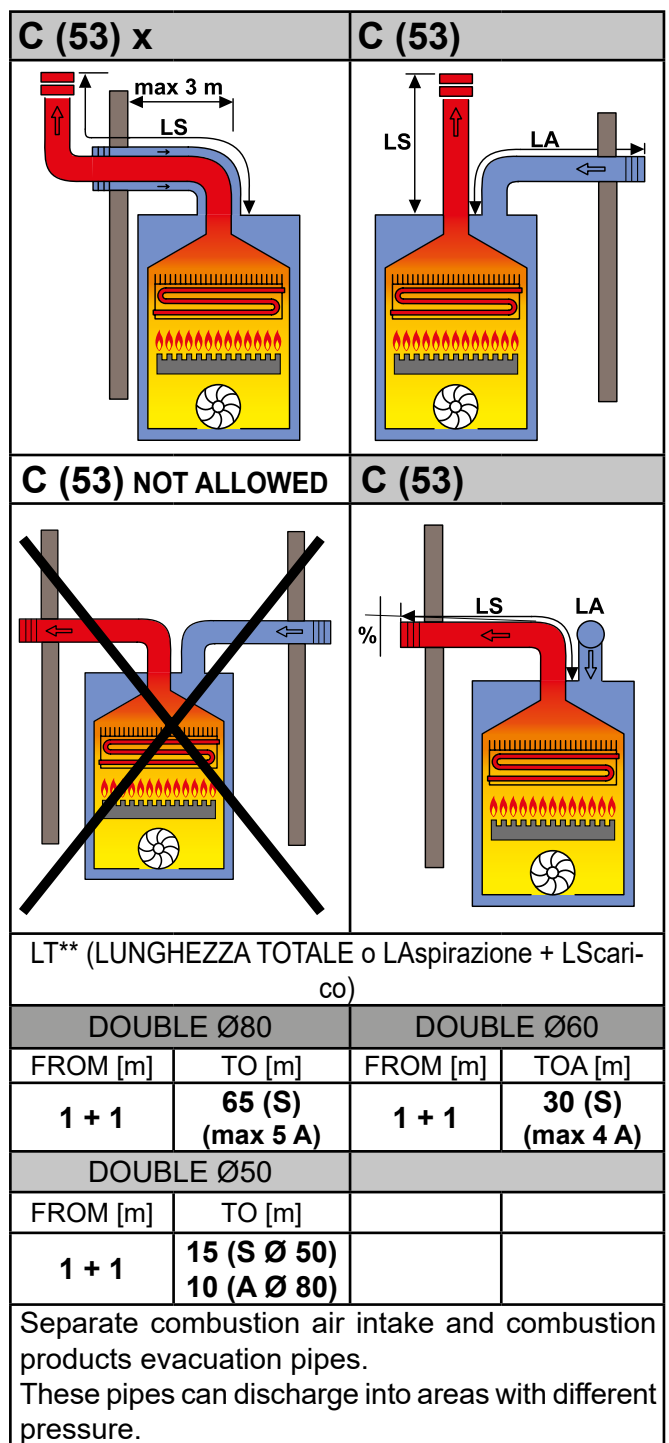

C63x	C63
<p>Boiler intended for connection to a combustion air intake and combustion products evacuation system, approved and sold separately</p>	
<p>Available head of the chimney base see tab. 2.4 operating data.</p>	

**Installation Instructions**

ENGLISH

 **ATTENTION:**  
The flue must comply with standards in force.

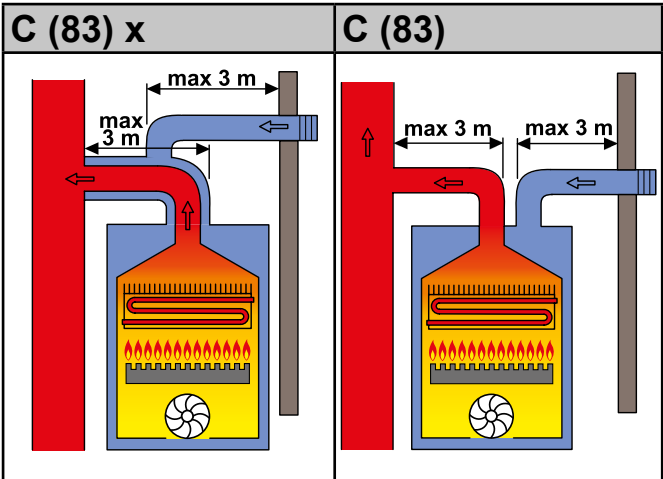

Connection to a terminal for combustion air intake and flue gas exhaust via a single or collective chimney.

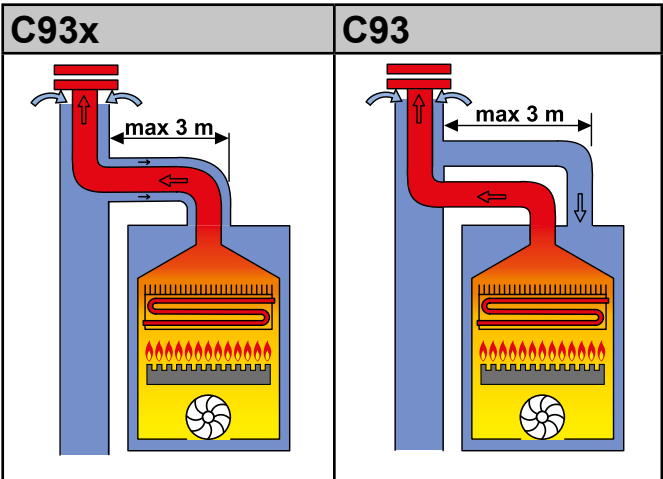

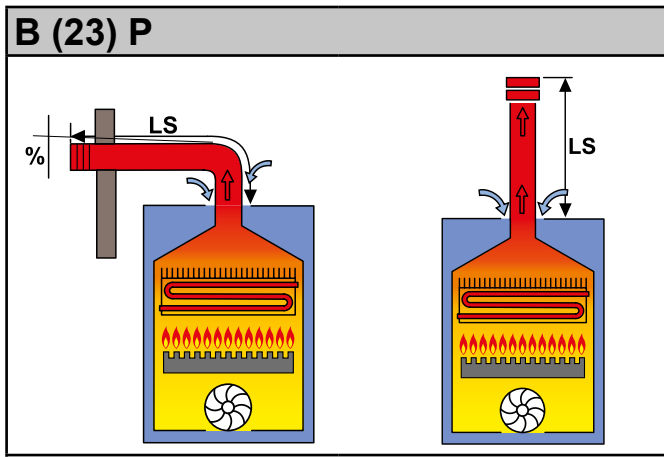

Air / flue gas through concentric pipes in the boiler room and single pipes in the chimney (combustion air with counterflow in the chimney)



TOTAL LENGTH (LS)	
DOUBLE Ø80	
FROM [m]	TO [m]
1	65
DOUBLE Ø60	
FROM [m]	TO [m]
1	30
DOUBLE Ø50	
FROM [m]	TO [m]
1	15

Connection to a combustion products evacuation pipe outside the room; the combustion air is taken directly from the room where the appliance is installed.

 **ATTENTION**  
Ø 50 smoke exhaust, only for type B23Pand C53 type.

 **ATTENTION:**  
For the type of connection B23P the room follows the same installation rules for boilers with natural draught.

### 3.6.1 - Installation on collective flues in positive pressure

The collective flue is a smoke exhaust system suitable for collecting and expelling the combustion products of multiple appliances installed on multiple floors of a building.

Positive pressure collective flues can only be used for type C condensing appliances. Consequently, the B53P / B23P configuration is prohibited.

The installation of boilers on pressurized collective flues is permitted exclusively to G20.

The boiler is sized to function correctly up to a maximum internal pressure of the flue not exceeding 25 Pa.

Make sure that the air intake and combustion product exhaust ducts are watertight.



**Note:**  
for use in configuration **C (10)**  
with optional clapét  
(only for G20 methane).

It is possible to install the appliance in configuration **C (10)** only with the optional accessory "clapét" provided by Unical.

Use of clapét as an accessory and requires a dedicated set of parameters to compensate the pressure drop introduced.



**Note:** Parameters are released by after-sales service upon request of installer / reserved technical area site.

ENGLISH

#### C(10) 3 x

#### C(10) 3

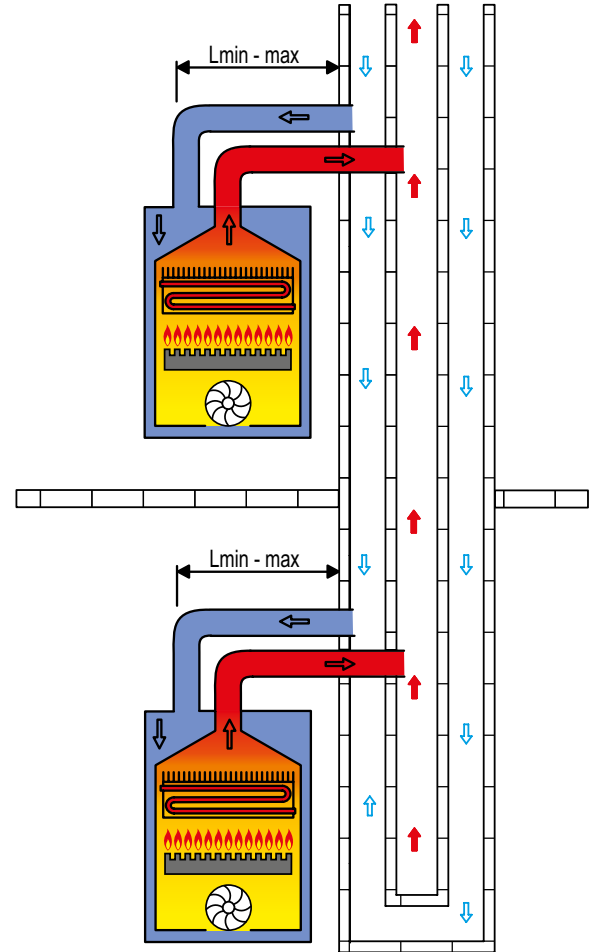
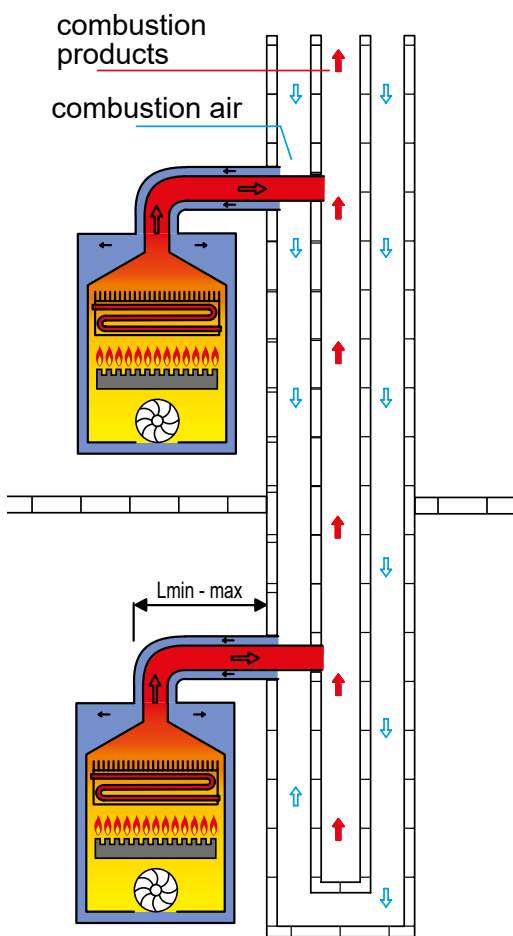

Installation Instructions

Slope towards the entrance = 3%

**Lmin-Lmax** (Minimum and maximum LENGTH at the flue entrance)

COAXIAL Ø60/100		DOUBLE Ø80	
FROM [m]	TO [m]	FROM [m]	TO [m]
-	-	<b>0,5+0,5</b>	<b>4,5+4,5</b>
COAXIAL Ø80/125			
FROM [m]	TO [m]		
<b>0,5</b>	<b>4,5</b>		

Horizontal exhaust and intake terminals directed externally via coaxial or split type ducts.

## GENERAL INFORMATION ON THE FLUE GAS EXHAUST SYSTEM



Per sistemi coassiali, montare il collare 3 (contenuto nei kit fumi coassiali) come indicato.

**Warning: DO NOT remove the rubber cap mounted on the hole of air inlet  $\varnothing$  80 A2**

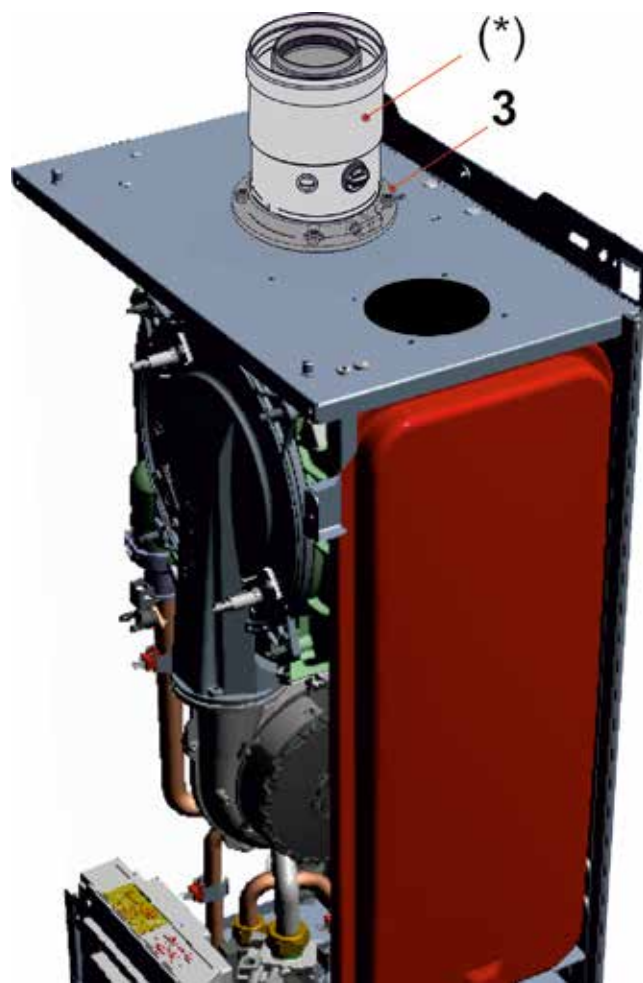
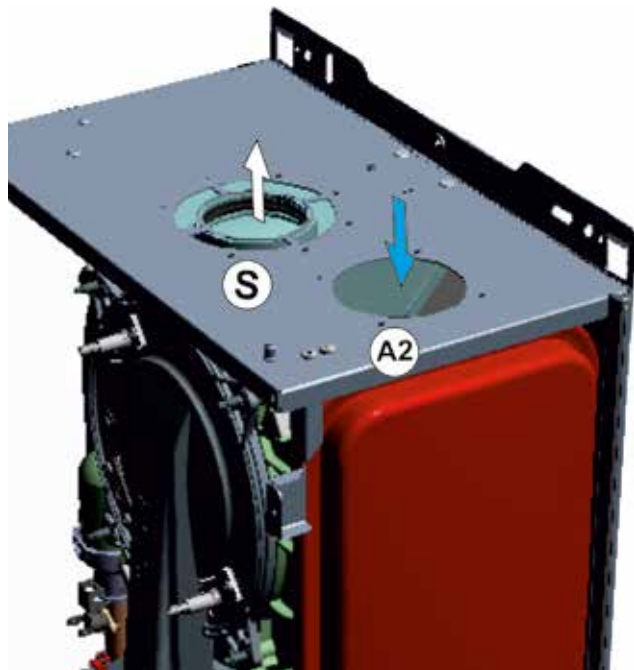

**KIT A coax.  $\varnothing$  100/60 = 00364813**

00364815 (\*)

00363307 (\*)

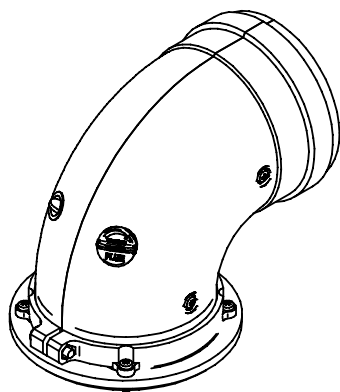
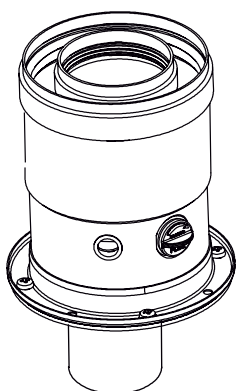

**Coaxial inception**





**For double systems**

**Use system adapters split (\*) as indicated.**

**Attention: remove the cap of clasp mounted on the hole of air inlet Ø 80 A2**

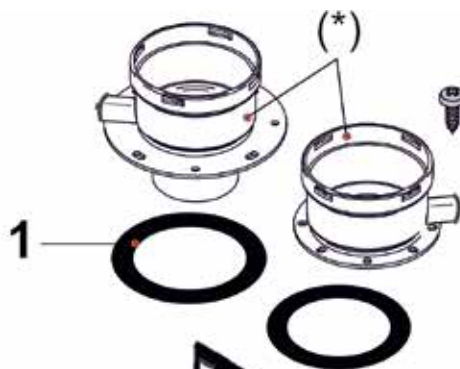
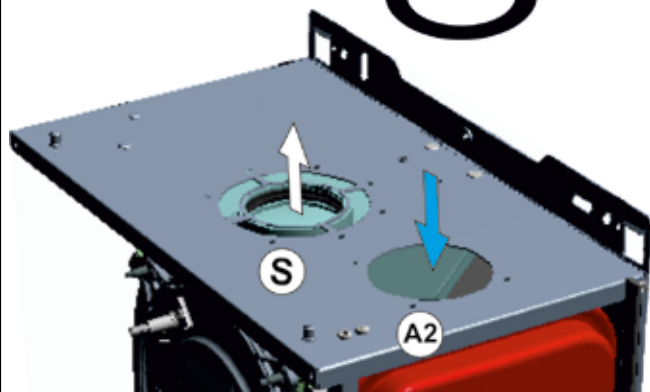
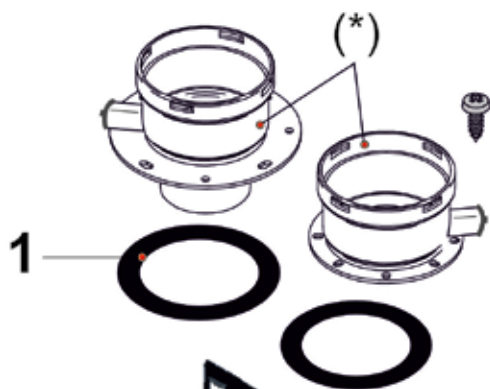

**KIT B double Ø 80 = 00364891**

00364817 (\*)

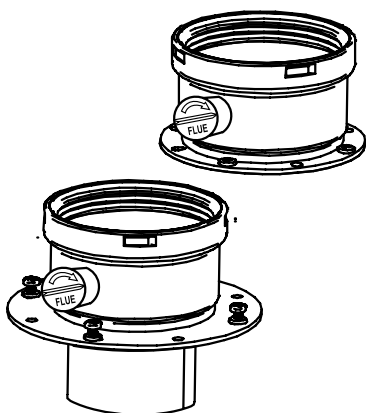

**Adapter for double systems**

**For split systems**

Use system adapters split (\*) as indicated.

Attention: remove the cap closure mounted on the hole of air inlet Ø 80 A2



### For double systems

Attention: remove cap closure **A2** mounted on hole of air inlet  $\varnothing$  80

### Type B22 for outdoor installation

00363902

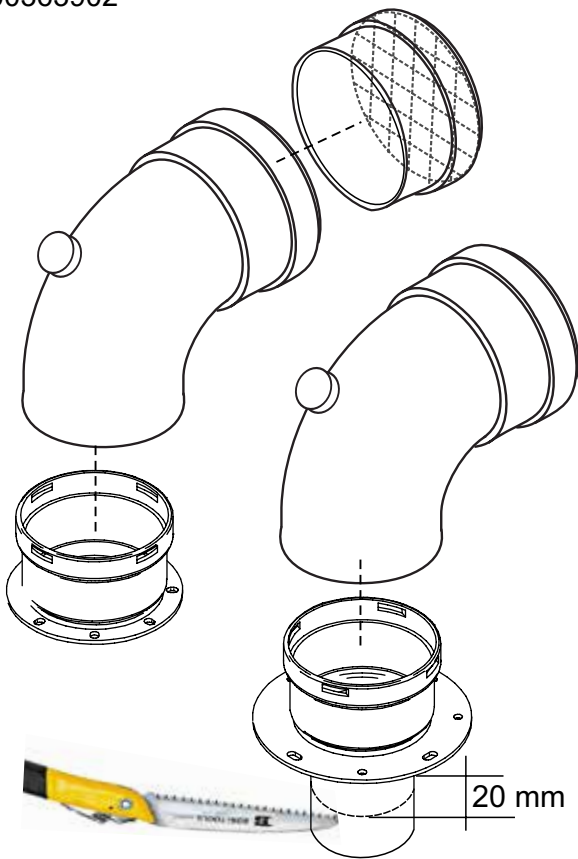

Note: Cut a to the indicated measure



### NOTE!

For further details relating to pressure drops of the individual components, for information on standards, rules and regulations for proper flue gas exhaust, refer to the "Technical Information" section on the boiler page of the [www.unicalag.it](http://www.unicalag.it) website



It is recommended to only use original Unical exhaust pipes.

The supplier will have no contractual or extra-contractual liability for damage caused due to incorrect installation and use and in any case failure to comply with the instructions provided by the manufacturer.

### 3.7 - CONNECTION

<b>G</b>	<b>GAS</b>	3/4"
----------	------------	------



#### Danger!

The gas connection must be carried out only by a qualified installer who must respect and apply that foreseen by relevant laws in force in the local prescriptions of the supply company. Incorrect installation can cause damage to persons, animals and objects for which the manufacturer cannot be held responsible.

#### If you smell gas:



- Do not operate electric switches, the telephone or any other object that may cause sparks;
- Immediately open doors and windows to create air current to purify the room;
- Shut the gas cocks.

<b>M</b>	<b>FLOW</b>	3/4"
<b>R</b>	<b>RETURN</b>	3/4"

<b>C</b>	<b>HOT</b>	1/2"
<b>F</b>	<b>COLD</b>	1/2"

<b>Sc</b>	<b>BOILER DRAIN</b>
<b>S.cond</b>	<b>CONDENSATION DRAIN</b>
<b>Rc</b>	<b>FILLING VALVE</b>
<b>Svs</b>	<b>SAFETY VALVE DRAIN</b>
	Provide a drain pipe with funnel and a trap that lead to a suitable drain, in correspondence of Svs. This drainage must be controlled on sight. <b>If this precaution is not taken, triggering of the safety valve can cause damage to persons, animals and objects, for which the manufacturer cannot be held responsible.</b>



The mains pressure must be within 1 and 3 bar (in the event of greater pressure install a pressure reducer).

#### Condensation drain

The boiler, during the combustion process, produces condensation that, through pipe "A", flows into the trap.

The condensation that forms inside the boiler flows into a suitable drain via pipe "B".



#### Danger!

Before commissioning the appliance:

- check that the trap is assembled properly
- check that the condensation is drained properly

Check after few minutes of operation there are no combustion fumes from the condensate drain.

#### Siphon connection

the siphon is fitted inside the boiler as shown (26)





Connect corrugated tube (27) on the siphon, using spring 28 (as indicated).



Condensation outlet, pipe to be connected to the drainage system



The connection between the appliance and the domestic waste system must be made in compliance with the specific reference standards.

**NOTE!**

Further details in the section “Technical Information” on the boiler page of the [www.unicalag.it](http://www.unicalag.it) website



**Danger of burns!**  
Attention to contact with flow pipe M and (if boiler combi) with hot water outlet pipe C.

### 3.8 - FILLING THE SYSTEM



**Attention!**

Do not mix the heating water with incorrect concentrations of antifreeze or anti-corrosion substances! This could damage the gaskets and cause noise during operation.

Unical will not be held liable for damage to persons, animals or objects due to failure to comply with the above instruction.

When the system connections have been completed, the circuit can be filled.

This operation must be performed carefully, respecting the following phases:

- open the radiator vent valves and make sure the automatic valve is working properly in the boiler.
- open the filling tap gradually, making sure that the automatic air release valves installed on the system work properly.
- close the radiator air release valves as soon as water comes out.
- check the pressure gauge until pressure reaches approximately 0.8/1 bar.
- close the filling tap and bleed air once again through the radiator air release valves.



- make sure that all the connections are watertight.
- after commissioning the boiler (see par. 3.10) and bringing the system to the operating temperature, stop the boiler and repeat the air bleed operations.
- let the system cool down and, if necessary, return the water pressure to 0.8/1 bar. (See par. 4.4).

### 3.9 - ELECTRICAL CONNECTIONS



**Danger!**  
Only a qualified technician may perform the electrical installation.  
Before performing connections or any

type of operation on electrical parts, always disconnect electrical power and make sure that it cannot be reconnected accidentally.



**Attention, before rotating or removing the panel. Disconnect the gray ignition lead.**

**ON/OFF room thermostat connection RT/OT (\*)**

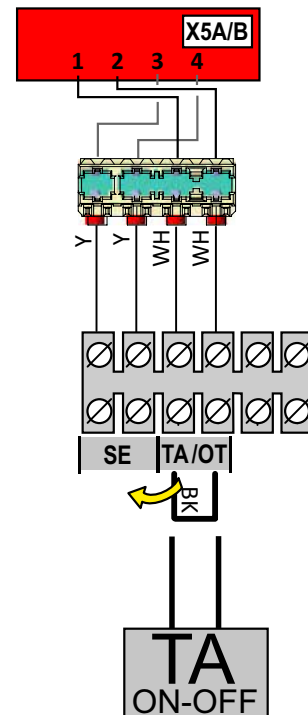

Connect room thermostat wires between terminals **TA/OT** after having removed the jumper

### ON/OFF room thermostat connection TA/OT (\*)



Thermostat Type Selection  
(Enable parameter A21 = 1)  
see chap. 4.7  
PARAMETER  
SETTINGS

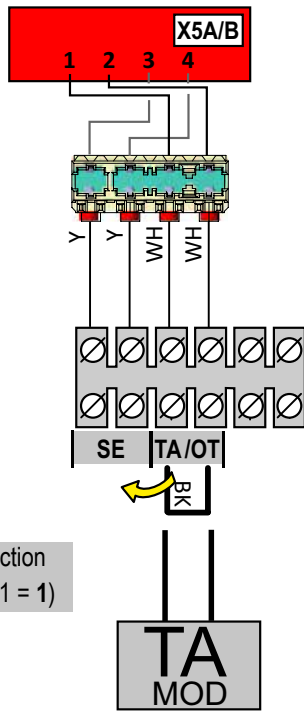

Connect the modulating thermostat wires between terminals **TA/OT** after having removed the jumper

### External probe connection (\*)

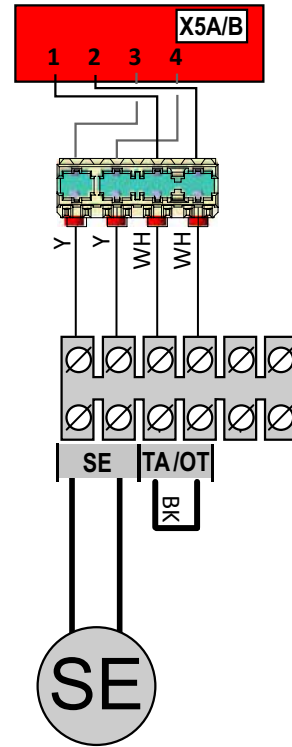

- Predisposed on the terminal board, terminals **SE**

### Electric power supply connection

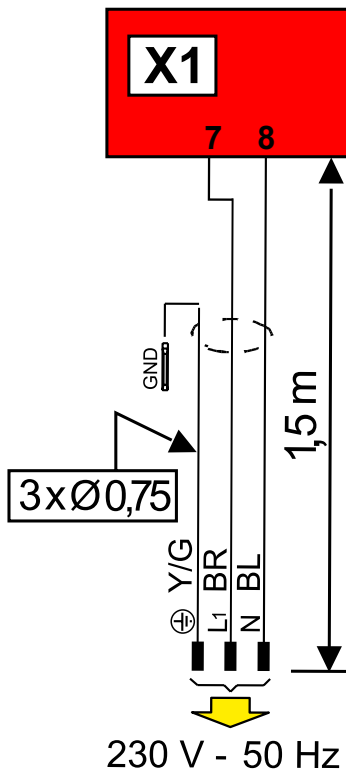

The boiler is equipped with a power cable, boiler installation requires electric al connection to the mains power supply. This connection must be made up to standard, as required the regulations in force.



Remember that a bipolar switch must be nstalled on the boiler power line with over 3 mm between contacts, easy to access, making maintenance quick and safe.



The power cable must be replaced by technical personnel authorised by **UNI-CALAG S.p.A.**, using original spare parts only. Failure to comply with the above can jeopardise the safety of the appliance.

See par. 4.5 positioning on the board  
(\*) **Optional**

### 3.10 - COMMISSIONING



Commissioning must be done by professionally qualified personnel. Unical AG S.p.A. will not be held liable for damage to persons, animals or objects due to

failure to comply with the above instruction. Before commissioning the boiler, check that:

does the installation meet the specific standards and regulations in force, both relating to the gas part as well as the electrical part?	<input type="checkbox"/>
do the combustion air intake and flue gas exhaust take place properly according to what is defined by the specific rules and regulations in force?	<input type="checkbox"/>
is the fuel supply system sized according to the capacity required by the boiler? Is it equipped with all safety and control devices required by the standards in force?	<input type="checkbox"/>
is the power supply of the boiler 230V - 50Hz?	<input type="checkbox"/>
has the system been filled with water (approximately 0.8/1 bar pressure on the pressure gauge with the pump stopped)?	<input type="checkbox"/>
Has the condensate drain trap been installed correctly as indicated in chapter 3.7?	<input type="checkbox"/>
are any system shut-off gate valves open?	<input type="checkbox"/>
does the gas to be used correspond to the boiler calibration gas?: otherwise, perform the boiler conversion in order to use the gas available (see section: 4.3”); this operation must be carried out by technical staff qualified in compliance with the standards in force;	<input type="checkbox"/>
is the gas supply valve open?	<input type="checkbox"/>
has the system been checked for gas leaks?	<input type="checkbox"/>
is the outside main switch ON?	<input type="checkbox"/>
is the system safety valve efficient and is it connected to the drains? is the condensation drain trap connected to the drains?	<input type="checkbox"/>
has the system been checked for water leaks?	<input type="checkbox"/>
are the ventilation conditions and minimum distances to perform any maintenance ensured?	<input type="checkbox"/>
have the GAS, HEATING and DOMESTIC HOT WATER pipes been cleaned thoroughly with products suitable for each circuit?	<input type="checkbox"/>
has a surveillance and protection system against gas leaks been installed? (Optional)	<input type="checkbox"/>
are the system pipes NOT used as the electrical system earthing?	<input type="checkbox"/>
has the system been sized properly bearing in mind the radiator pressure drops? thermostatic valves, radiator stop valves	<input type="checkbox"/>
has the operator been trained and has the documentation been supplied?	<input type="checkbox"/>
Please tick the operations performed	

ENGLISH

Installation Instructions

#### Switching boiler on and off

#### NOTE!

For further details refer to the Technical Information from the website (link at page 2).

### 3.10.1 - AIR BLEED FUNCTION OF BOILER / SYSTEM (AP)

The air bleed function is activated every time the boiler is powered electrically (Power ON).

The procedure has a duration of 10 minutes and for the entire time of the procedure the display shows **AP** flashing.

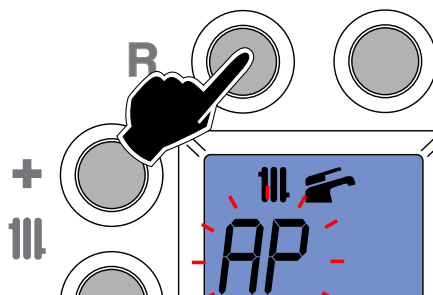
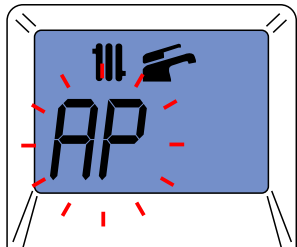

Note.

The procedure can be forced to interrupt by pressing the release button for 1 s.

- In case of DHW request, the procedure is interrupted and at the end of the request is restarted.

## 3.11 - MEASUREMENT OF COMBUSTION EFFICIENCY DURING INSTALLATION

### 3.11.1- ACTIVATION OF THE CALIBRATION FUNCTION



**ATTENTION!**  
Function reserved for Authorised Assistance Centres only.

The user is **NOT** authorised to activate the function described below.

**1 ACTIVATION**

Press the {Reset} and {Minus DHW} keys simultaneously for 3 seconds. In this case the message H0x is displayed where x can assume values from 0 to 3 based on the type of chimney sweep function selected:

**2 IGNITION LEVEL**

The symbols (CH radiator and DHW tap on the display) they flash

**3 MAXIMUM OUTPUT**

Pass from the value H00 (ignition level) to the value H01 (power min) to the value H02 (power max) or value H03 (power max CH) **the boiler operates at maximum power.**  
Make combustion analysis

**4 MINIMUM OUTPUT**

Pass from the H02 or H03 (power max) value to the H01 value **the boiler works at minimum power.**  
Make combustion analyses



## 5 DISABLING

The "TEST MODE" function remains active for 15 minutes.

To stop TEST MODE function before the time expires, press the (mode) key.



**Note:**  
This function does not allow any adjustment of CO<sub>2</sub> levels on min/max power. If you need to apply correction to CO<sub>2</sub> values (Ref. par. 3.12.1).

### 3.11.2 - POSITIONING THE PROBES

To determine the combustion efficiency one must make the following measurements:

- measurement of the combustion air temperature taken in the relevant hole 1.
- measurement of the flue gas temperature and content of CO<sub>2</sub> taken in the relevant hole 2.

Take the measurements with the generator in steady state conditions (see par. 3.11.1).



**N.B.:** Insert the smoke probe only afterwards ignition of the burner, this in order to avoid saturation of the analyzer cells.

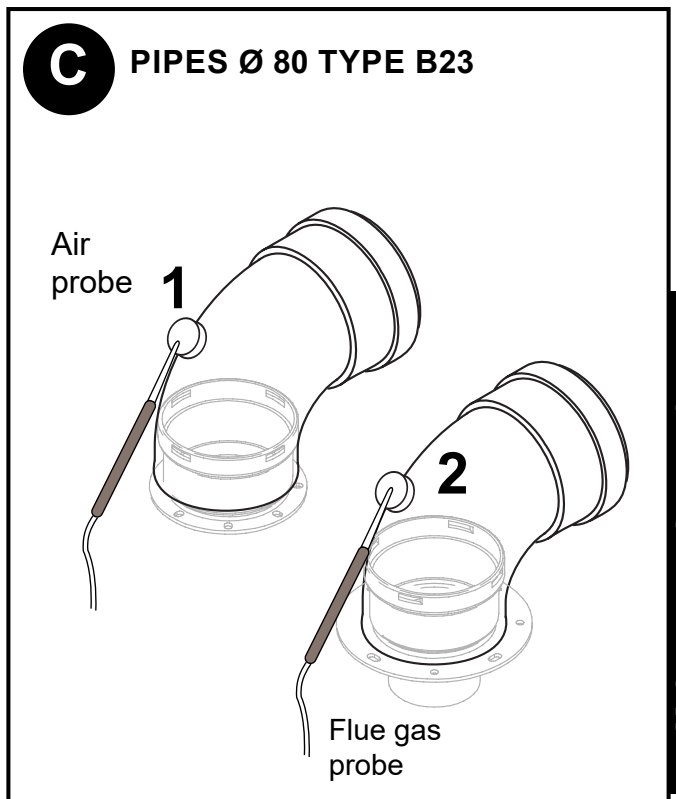
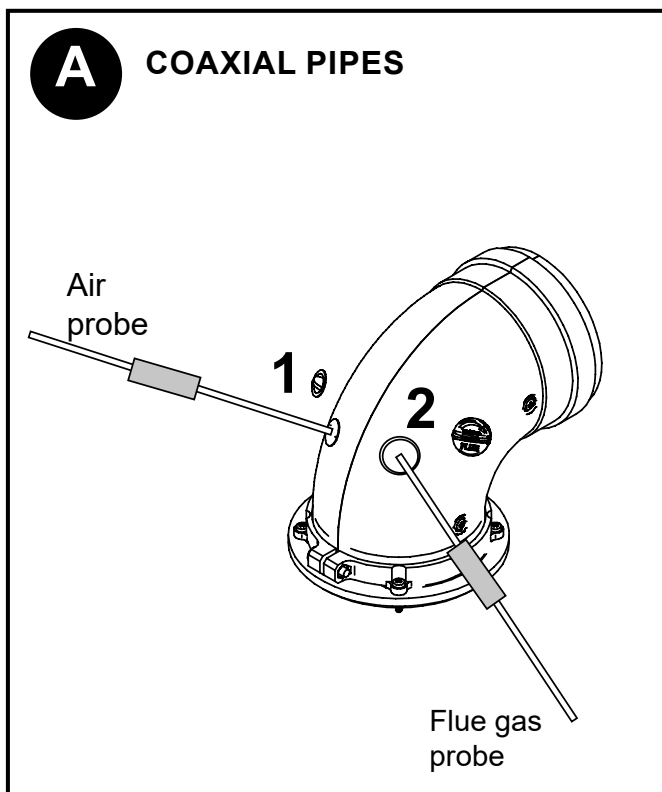
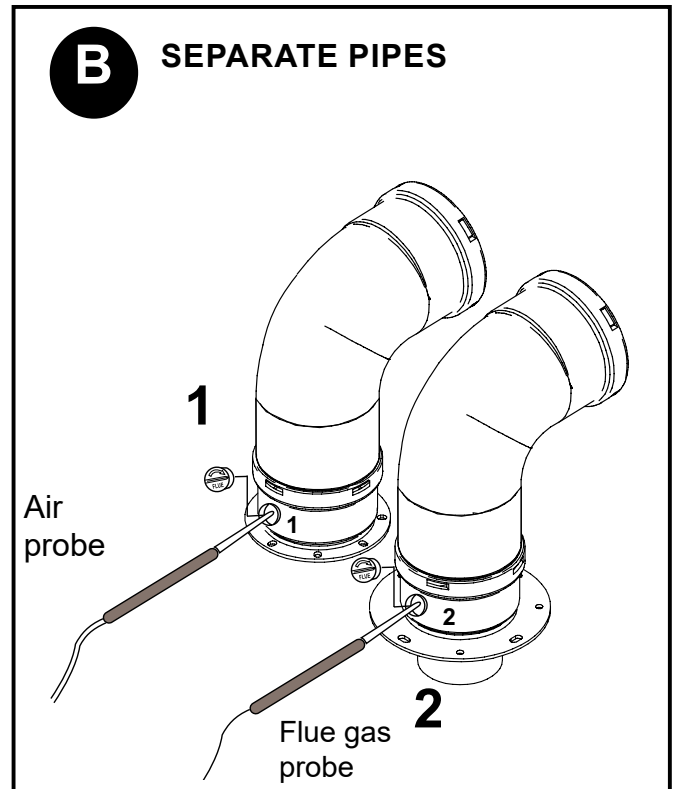

### 3.12 -ADJUSTING THE BURNER



In order for the boiler to work properly the content of CO<sub>2</sub> must comply with the tolerance field of the table below.

### NOZZLES - PRESSURE - FLOW RATES TABLE

Check the levels of CO<sub>2</sub> often, especially with low flow rates. They refer to the boiler with a closed combustion chamber.

EK! R18 - C18 (referring data to CH mode)														
Type of Gas	Effective Output [kW]	Heating Thermal Capacity [kW]	Supply Press. [mbar]	Fan speed [rpm]		Collector diaphragm [Ø/n. holes]	Dia-phragm VG [Ø]	CO <sub>2</sub> levels [%]		(*) - Levels O <sub>2</sub> [%]		Consumpt. [m <sup>3</sup> /h] [kg/h]	Consumpt. [m <sup>3</sup> /h] [kg/h]	Start-up power IG [%]
				min	max			min	max	min	max			
Nat. gas (G20)	2,8 - 17,5	3 - 18	20	1300	5600	-	-	9	9	4,8%	4,8%	0,32	1,90	3800
Nat. gas (G25)	2,8 - 17,5	3 - 18	25	1300	5600	-	-	9	9	-	-	0,37	2,21	3800
Propane (G31)	4,5 - 17,5	4,6 - 18	37	1700	5300	-	-	10,0	10,0	-	-	0,19	1,40	3800
± 0,2 Acceptable range of CO <sub>2</sub> for G20 / G25						± 0,2 Acceptable range of CO <sub>2</sub> for G31								
± 0,4 Acceptable range of O <sub>2</sub> for 20%H <sub>2</sub> NG														

EK! R20 - C20 (referring data to CH mode)														
Type of Gas	Effective Output [kW]	Heating Thermal Capacity [kW]	Supply Press. [mbar]	Fan speed [rpm]		Collector diaphragm [Ø/n. holes]	Dia-phragm VG [Ø]	CO <sub>2</sub> levels [%]		(*) - Levels O <sub>2</sub> [%]		Consumpt. [m <sup>3</sup> /h] [kg/h]	Consumpt. [m <sup>3</sup> /h] [kg/h]	Start-up power IG [%]
				min	max			min	max	min	max			
Nat. gas (G20)	2,8 - 19,5	3 - 20	20	1300	6000	-	-	9	9	4,8%	4,8%	0,32	2,11	3800
Nat. gas (G25)	2,8 - 19,5	3 - 20	25	1300	6000	-	-	9	9	-	-	0,37	2,46	3800
Propane (G31)	4,5 - 19,5	4,6 - 20	37	1700	5800	-	-	10,0	10,0	-	-	0,19	1,55	3800
± 0,2 Acceptable range of CO <sub>2</sub> for G20 / G25						± 0,2 Acceptable range of CO <sub>2</sub> for G31								
± 0,4 Acceptable range of O <sub>2</sub> for 20%H <sub>2</sub> NG														

EK! R24 - C24 (dati riferiti al funzionamento in riscaldamento)														
Type of Gas	Effective Output [kW]	Heating Thermal Capacity [kW]	Supply Press. [mbar]	Fan speed [rpm]		Collector diaphragm [Ø/n. holes]	Dia-phragm VG [Ø]	CO <sub>2</sub> levels [%]		(*) - Levels O <sub>2</sub> [%]		Consumpt. [m <sup>3</sup> /h] [kg/h]	Consumpt. [m <sup>3</sup> /h] [kg/h]	Start-up power IG [%]
				min	max			min	max	min	max			
Nat. gas (G20)	2,8 - 23,3	3 - 24	20	1300	7000	-	-	9	9	4,8%	4,8%	0,32	2,54	3800
Nat. gas (G25)	2,8 - 23,3	3 - 24	25	1300	7000	-	-	9	9	-	-	0,37	2,95	3800
Propane (G31)	4,5 - 23,3	4,6 - 24	37	1700	6900	-	-	10,0	10,0	-	-	0,19	1,86	3800
± 0,2 Acceptable range of CO <sub>2</sub> for G20 / G25						± 0,2 Acceptable range of CO <sub>2</sub> for G31								
± 0,4 Acceptable range of O <sub>2</sub> for 20%H <sub>2</sub> NG														



(\*) If a Hydrogen Ready installation is envisaged, for all calibration operations refer to the table overlying with the O<sub>2</sub> % content in the fumes. The O<sub>2</sub> values refer to the 20%H NG gas.



**Important**  
This appliance is suitable for the category containing up to 20% hydrogen (H<sub>2</sub>). Due to variations in the H<sub>2</sub> percentage, the O<sub>2</sub> percentage may vary over time depending on the quality of the gas supplied by the distributor. If a Hydrogen Ready installation is envisaged, refer exclusively to the O<sub>2</sub> value shown in the nozzles - pressures - flow rates table.



If the CO<sub>2</sub> value detected is outside the recommended range, check the integrity of the electrode. If necessary, replace the electrode. If the problem is not solved, you can use the function described below.

### 3.12.1 - COMBUSTION ADJUSTMENT FUNCTION

This function allows partial regulation of the CO<sub>2</sub> value (- 8 ÷ + 8 ) at the Minimum power (H01) and at the Maximum power (H02 / H03 CH in the case of a reduced power boiler).



To make the correction (after performing the combustion analysis) go to the parameter setting menu (see par. 4.7) ENTER WITH PSW.

**1 SETTING PARAMETER**

Access using the factory code (see par. 4.7)

1 - Scroll through the parameters with the {Minus CH} key up to parameter C07 (CHIMNEY SWEEP)

2 - Enter param C07 with {Plus DHW} key

3 - Change the value 00 to 02 (maximum power) with key {Plus DHW}

4 - Activate level 02 (maximum power) within parameter C07 chimney sweep press {MODE}

5 - the boiler goes to maximum power, with the analyzer inserted, check the level of Co 2 at max. (if ok exit {MODE}).

6 - otherwise press {Plus CH} to go to parameter C09 (CO2 adjust pot. max)

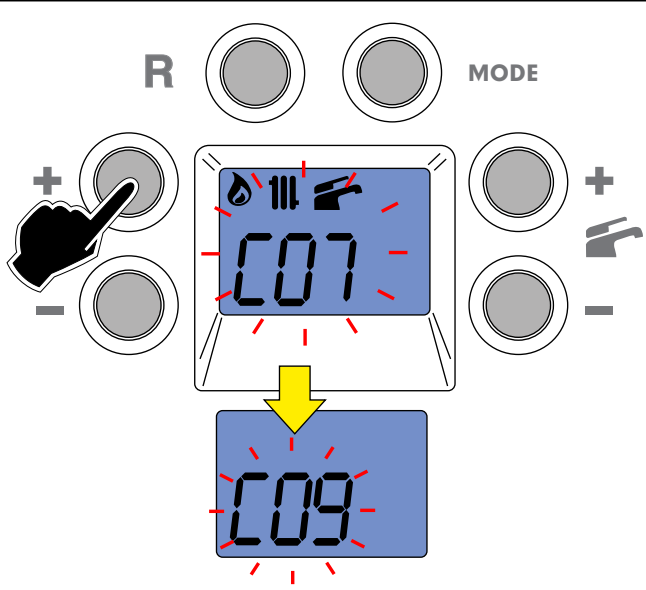

7 - Press {More DHW} to change value to decrease CO2 at max power. press {Minus DHW} (range -8 to +8)

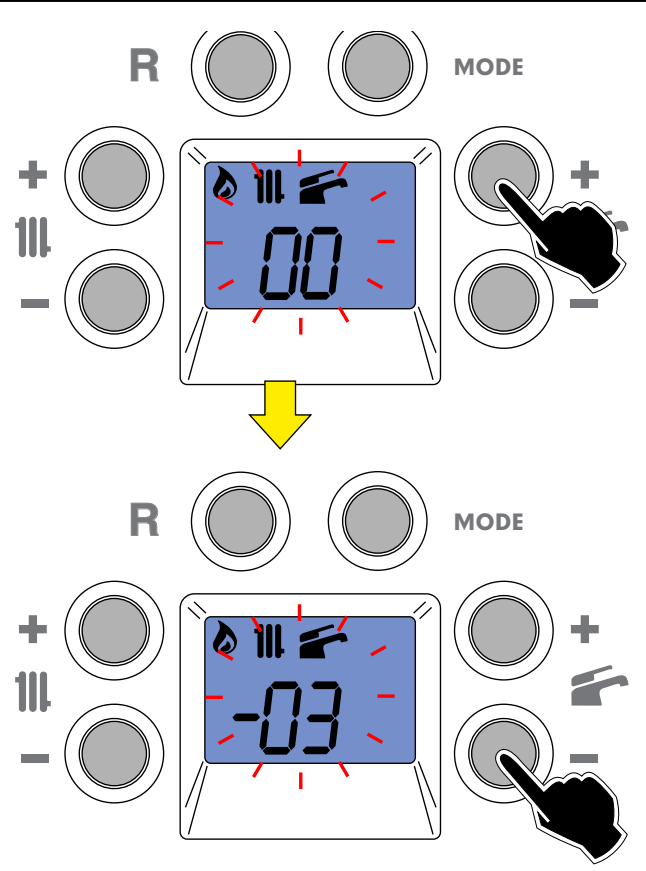

8 - Press the {MODE} key to confirm the value

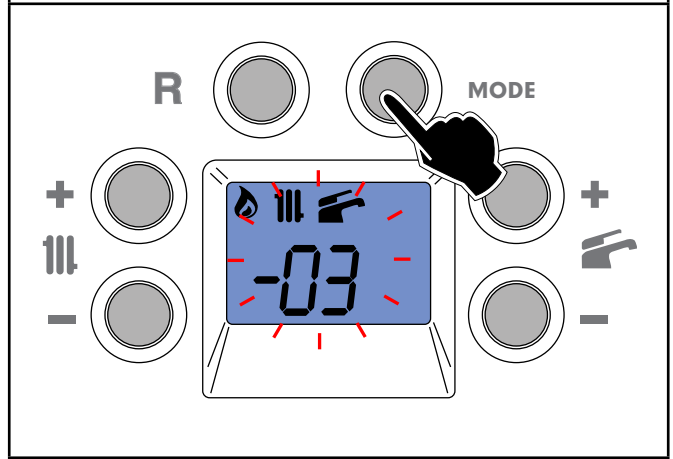

9 - Scroll through the parameters with the {Minus CH} key up to parameter C07 (CHIMNEY SWEEP)

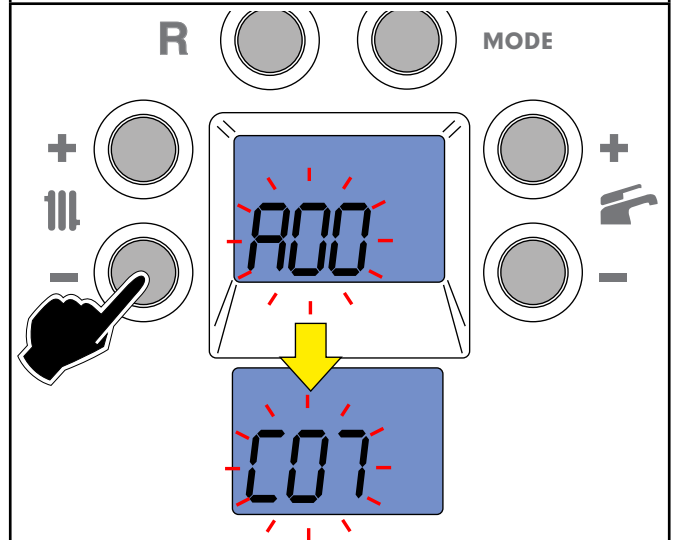

10 - Enter param C07 with key {Plus DHW}

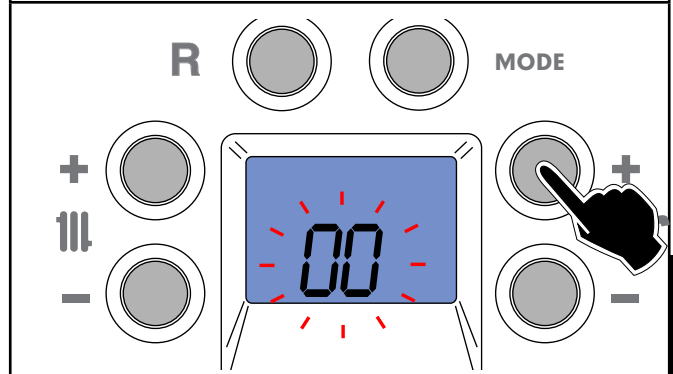

11 - Change the value 00 to 01 (minimum power) with key {Plus DHW}

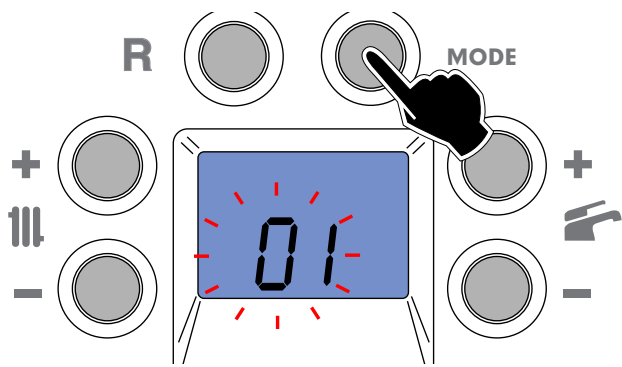

12 - Activate level 01 (minimum power) inside parameter C07 with {MODE}

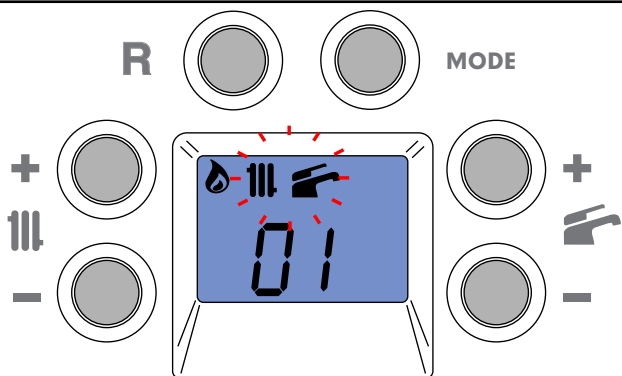

12 -the boiler goes to minimum power, with the analyzer inserted, check the Co 2 level at min power. (if ok exit {MODE}).

13 - otherwise press {Plus CH} 2 times to go to parameter C08 (CO2 adjust power min)

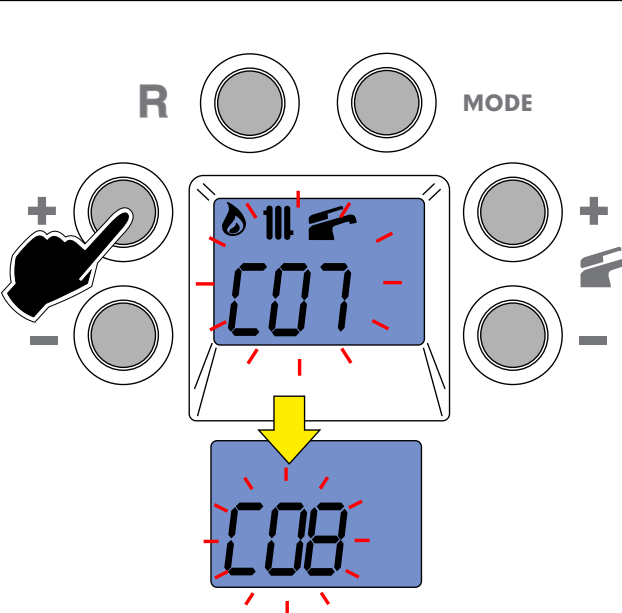

14 - press {More DHW} to change value to increase the CO2 to the min power. press {Plus or Minus DHW} (range -8 to +8)

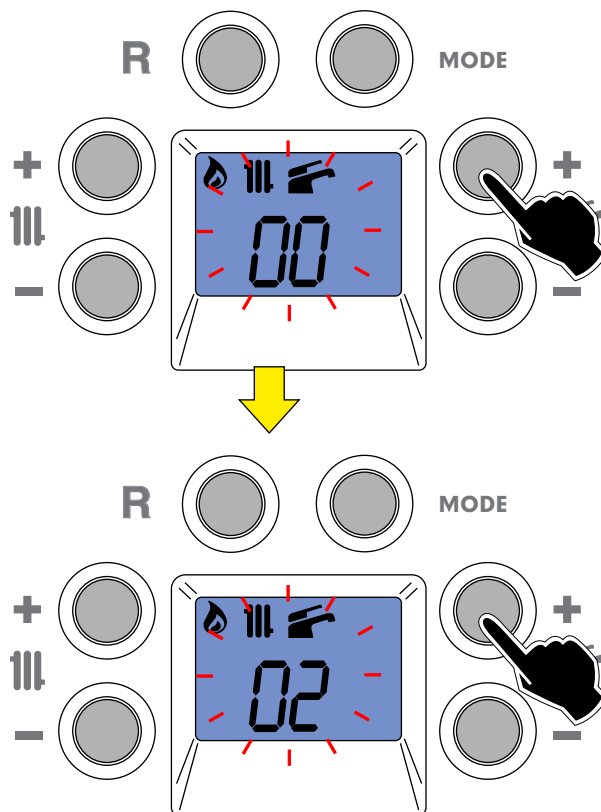

15 - Press the {MODE} key to confirm the value

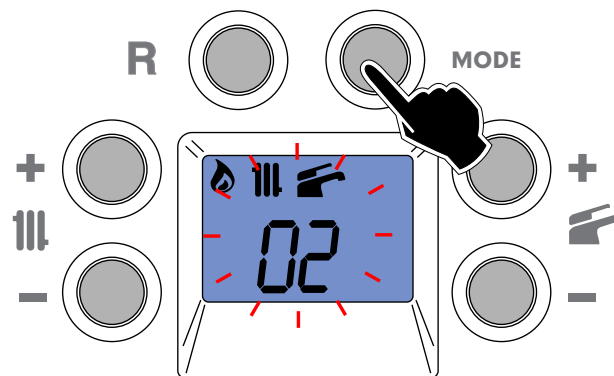

**Note:**

Once the CO2 correction has been completed, it is necessary to restore the value in parameter C07 (CHIMNEY SWEEP) to the value 0 = OFF. SEE NEXT PAGE.

# CHIMNEY SWEEP VALUE RESET

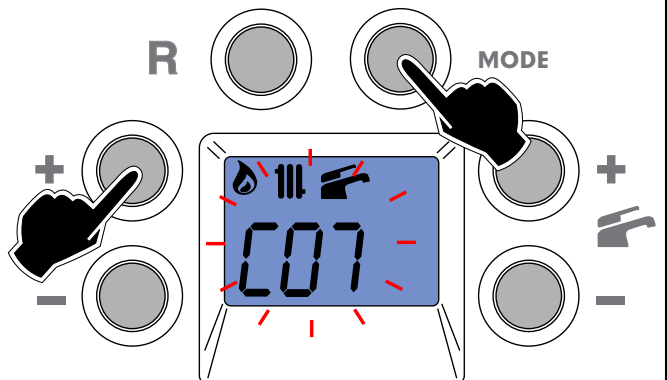
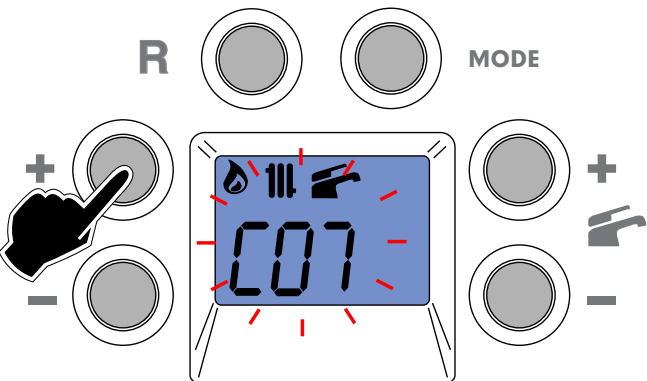
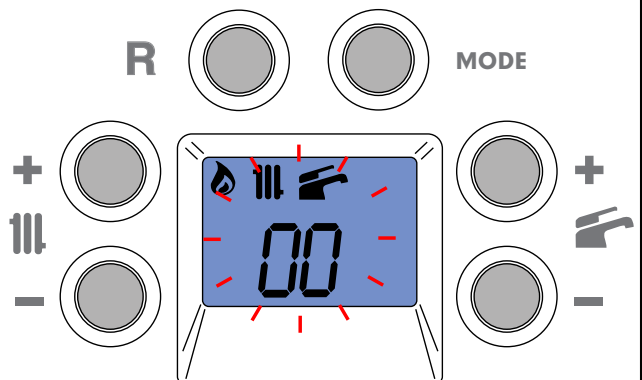
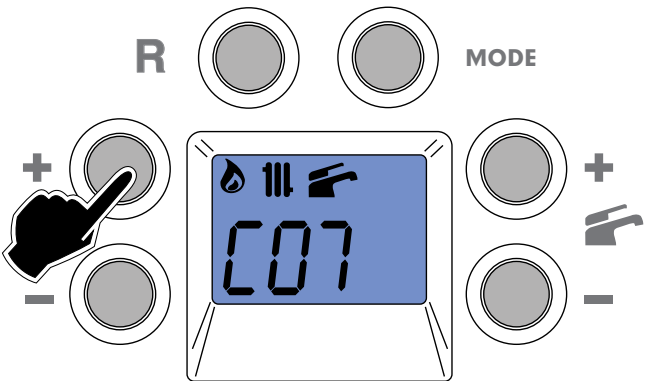
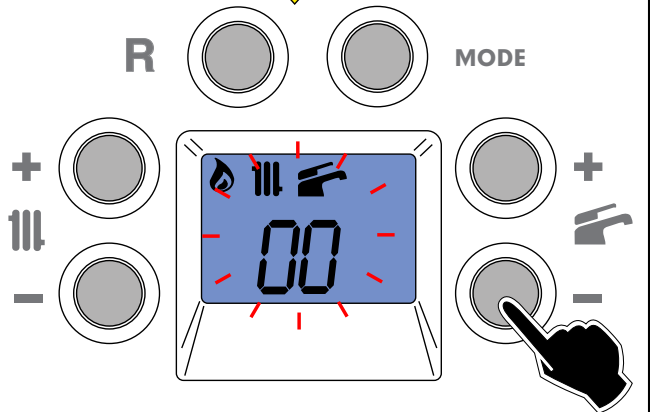
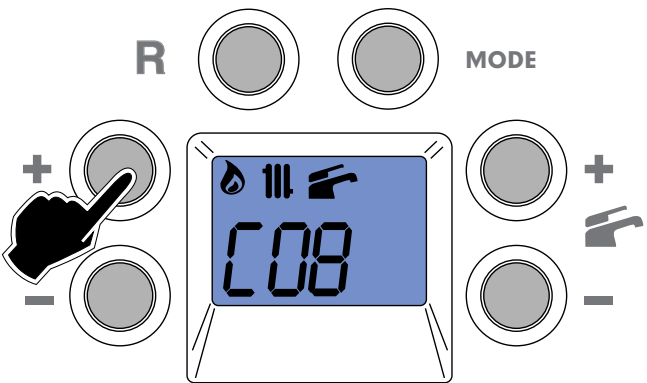
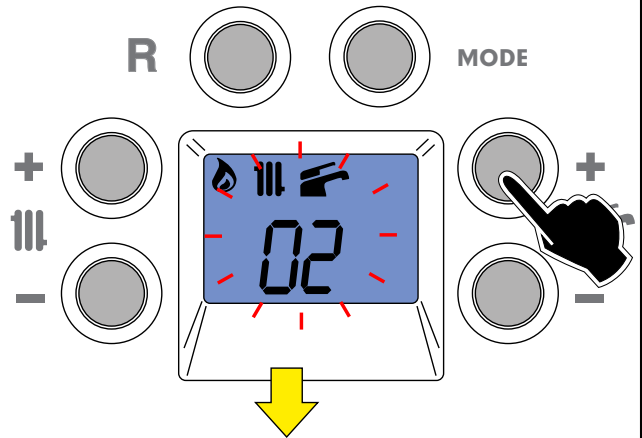
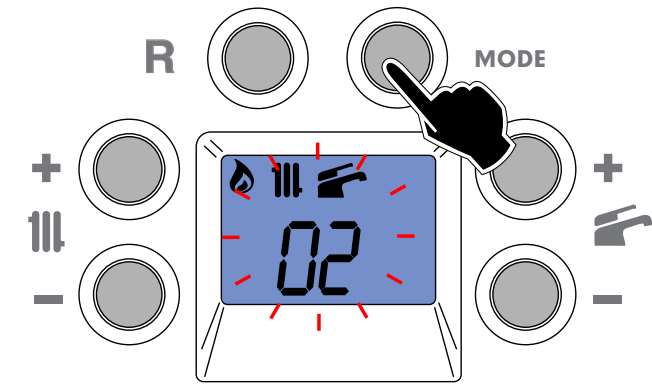

### 3.12.2 - ADAPTATION OF THE POWER TO THE HEATING SYSTEM



**ATTENTION!**  
**Function reserved for Authorised Assistance Centres only.**  
**The user is NOT authorised to activate the function described below.**

It is possible to adjust the maximum thermal capacity in heating mode, by decreasing the burner output value.

Act on parameter **A05** (par. 4.7 parameters that can be edited from control panel) to achieve the value corresponding to the desired output.

E.g.: **EK! - C 20**  
 to decrease the output of the boiler to 15 kW, edit parameter A05 (about 46).

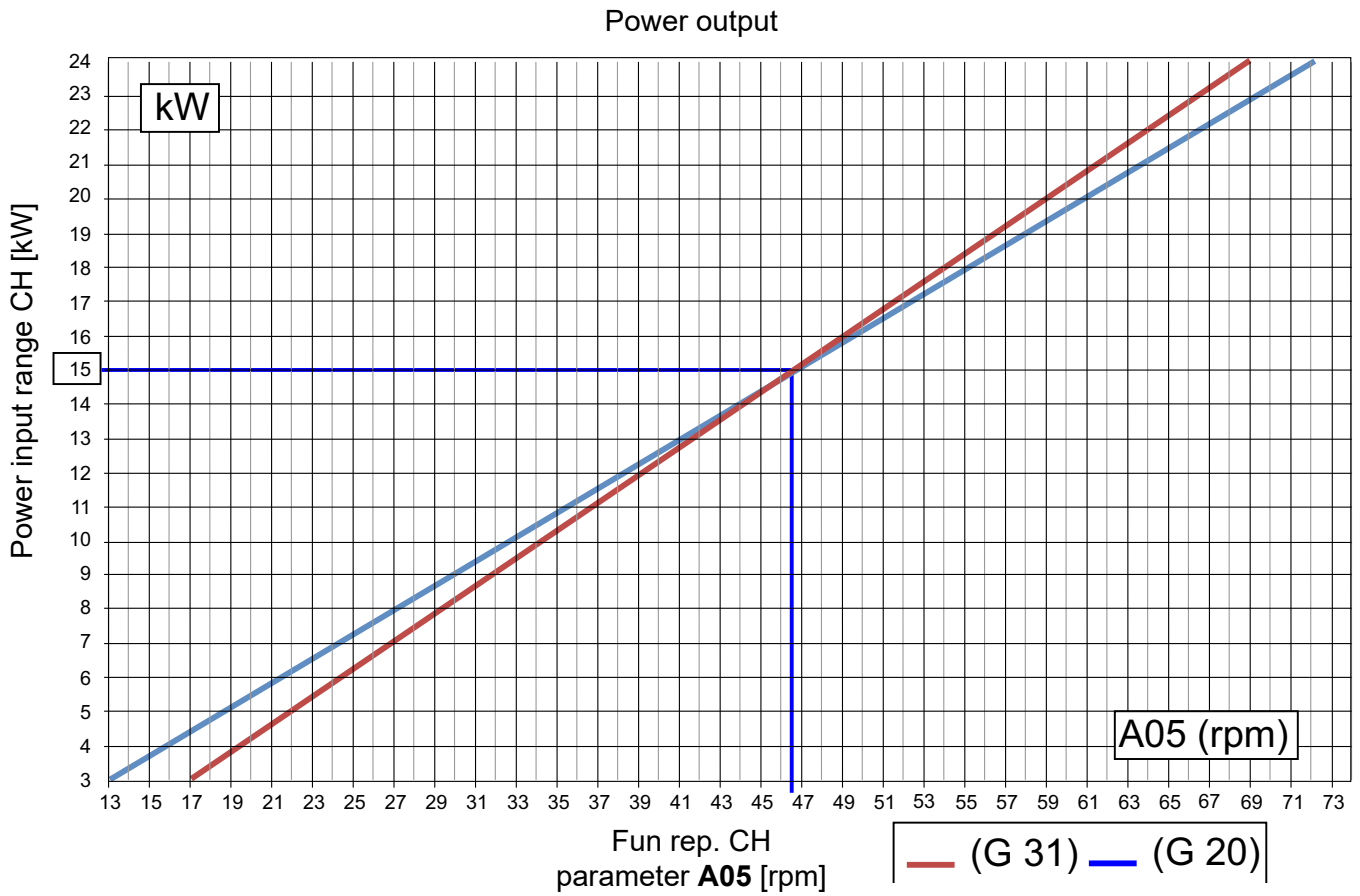



# 4

## INSPECTION AND MAINTENANCE



Inspections and maintenance performed professionally and according to a regular schedule, as well as the use of original spare parts, are of the utmost importance for fault-free operation of the boiler and to guarantee its long life.

Yearly maintenance of the appliance is mandatory in compliance with Laws in force.



Failure to perform Inspections and Maintenance can entail material and personal damage.

### 4.1 - INSPECTION AND MAINTENANCE INSTRUCTIONS

To assure long-term functioning of your appliance and to avoid altering its approved status, only original Unical spare parts must be used.

If a component needs to be replaced:

- Disconnect the appliance from the electrical mains and make sure that it cannot be reconnected accidentally.
- Close the gas shut-off valve upstream the boiler.
- If needed, and depending on the intervention to be carried out, close any shut-off valves on the flow and return line of the heating system, as well as the cold water inlet valve.

- Remove the front casing from the appliance.

Once all maintenance operations are complete resume boiler operation.

- Open the heating flow and return pipes, as well as the cold water inlet valve (if closed previously).
- Vent and, if necessary, restore the heating pressure until reaching a pressure of 0.8/1.0 bar.
- Open the gas shut-off valve.
- Switch the boiler on
- Make sure the appliance is gas tight and water-tight.
- Remount the front casing of the appliance.

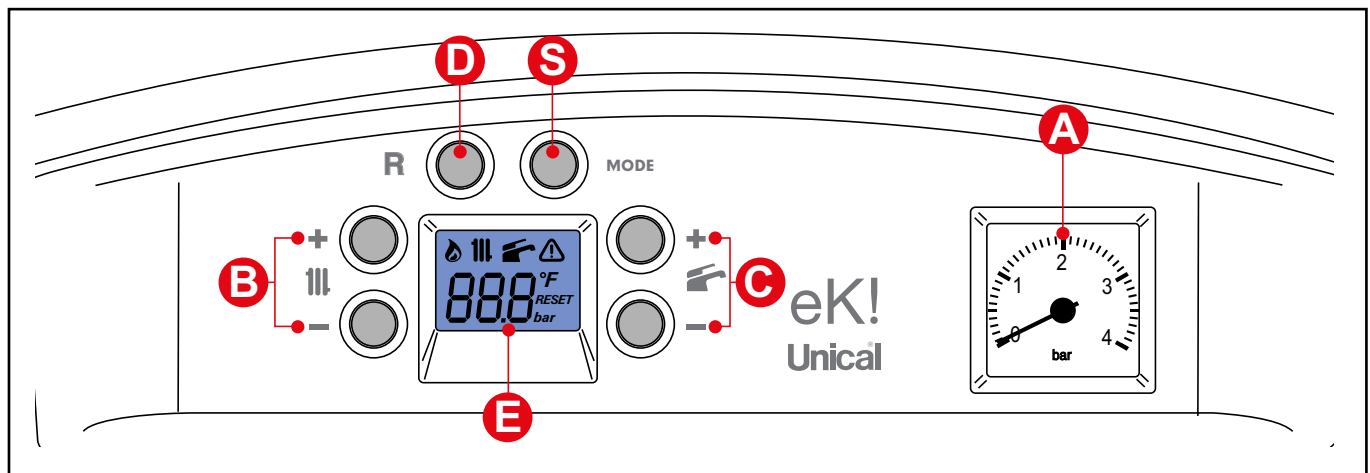

**TABLE OF RESISTANCE VALUES, ACCORDING TO THE TEMPERATURE, TO THE HEATING PROBE PROBE 1 (SS) AND ANY HEATING RETURN PROBE 22 (SRR) see par. 4.5.**

T°C	0	1	2	3	4	5	6	7	8	9
0	32755	31137	29607	28161	26795	25502	24278	23121	22025	20987
10	20003	19072	18189	17351	16557	15803	15088	14410	13765	13153
20	12571	12019	11493	10994	10519	10067	9636	9227	8837	8466
30	8112	7775	7454	7147	6855	6577	6311	6057	5815	5584
40	5363	5152	4951	4758	4574	4398	4230	4069	3915	3768
50	3627	3491	3362	3238	3119	3006	2897	2792	2692	2596
60	2504	2415	2330	2249	2171	2096	2023	1954	1888	1824
70	1762	1703	1646	1592	1539	1488	1440	1393	1348	1304
80	1263	1222	1183	1146	1110	1075	1042	1010	979	949
90	920	892	865	839	814	790	766	744	722	701

Relation between the temperature (°C) and the nom. resistance (Ohm) of the heating probe SR and of the domestic hot water probe SS

Example: At 25°C, the nominal resistance is 10067 Ohm    At 90°C, the nominal resistance is 920 Ohm

<b>ROUTINE YEARLY VERIFICATION OPERATIONS</b>		
<b>COMPONENT:</b>	<b>VERIFY:</b>	<b>CONTROL/INTERVENTION METHOD:</b>
FL (domestic hot water priority flow switch) ( 2 )	Is the minimum domestic hot water flow rate 3 l/min.?	The burner must ignite with an intake above or equal to: 3 l/min.
VG (Gas valve) ( 3 )	Does the valve modulate properly?	Open a hot water tap at maximum flow rate and then at minimum. Make sure that the flame modulates.
SR (heating sensor)( 11 ) SS (domestic hot water sensor) ( 1 ) SSR (return sensor) ( 22 )	Do the sensors maintain the original characteristics?	12571 ohm at 20° C / 1762 ohm at 70° C. Measurement to be taken with the wires disconnected (see table Res/Temp).
E ACC/RIV. (ignition/detection electrode) ( 4 )	Does the discharge of sparks before putting the boiler in safe conditions last less than 10 sec.?	Detach the electrode ionisation wire and check the securing time.
TL (anti-overheating limit thermostat) ( 10 )	Does the TL put the boiler in safety conditions when overheating?	Heat the TL until it intervenes at 95°C and check that it intervenes at 95°.
DK (safety pressure switch against water deficiency) ( 13 )	Does the pressure switch block the boiler if the water pressure is below 0.4 bar?	Without request: close the shut-off valves of the heating circuit, open the drain valve to make the water pressure decrease. Before pressurising again, check the pressure of the expansion vessel.
Expansion vessel ( 8 )	Does the vessel contain the right amount of air?	Check the pressure in expansion vessel (1 bar when the boiler is empty). Pressurise the boiler (open the pump automatic vent valve). Open the heating circuit closing valves.
Condensation drain trap (26)	Has the trap got deposits on the bottom?	Clean the trap with water.
Domestic hot water flow rate	Filter in cold water inlet ( 2 )	Clean the filter with limescale remover.
Heat exchanger body (24)	1) Measure the Thermal Capacity using a meter and compare the value with that contained in table 3.12. The data measured indicates if the exchanger needs cleaning.  2) Check that the space between the rungs of the exchanger are not clogged	It is recommended to use the products purposely created by Unical (see system protection ACCESSORIES sect. in the domestic price list), being careful to wash the area with most rungs first (lowest part visible from above) and then the upper part if necessary.
Burner ( 5 )	Check the state of cleanliness of the burner mesh	Remove any deposits using compressed air, blowing from the mesh side.
<b>( Num ) = see key Par. 2.2</b>		

## 4.2 - MENU INFO



### ATTENTION!

Function reserved exclusively for Authorized Assistance Centres.

Press the {Mode} key for 3 seconds to enter the information menu.

Inside the menu, the parameter number alternates with the relative value every 3 seconds.

Press the {Mode} key for 3 seconds to exit the information menu.

To reset the Error code (last 5 errors queue), position yourself on parameter n 11 (first alarm in the queue) and keep the {Plus CH} and {Plus DHW} keys pressed for 3 seconds.

The word “do” (done) will appear and then the queue will be restored.

The information available is as follows:

LABEL	DESCRIPTION	U.M.	Presence on menu
n00	SMG1 sensor temperature SMG1	°C	Always
n01	SMG2 sensor temperature SMG2	°C	Always
n02	SS sensor temperature SS	°C	Always
n03	Return sensor temperature	°C	Only if sensor is connected and not damaged
n04	Exhaust sensor temperature	°C	Always
n05	External sensor temperature	°C	Only if sensor is connected and not damaged
n06	Target Fan speed	rpm/100	Always
n07	Iono flame	uA	Always
n08	PWM pump speed percentage	% duty	Only with PWM pump setting (A23=1)
n09	Fan speed	rpm/100	Always
n10	“Used to show “A L” or “n F” indication for tank configuration”	---	Only for storage tank setting (A00=1)
n11 ÷ n15"	Error code (queue last 5 errors)	---	Always
n16	Setpoint used for thermoregulation	°C	Always
n17	DHW Setpoint temperature	°C	Only if storage tank enable
n18	Days remaining before show Service warning (SEr)	---	Only if function enable
n20	Burner working weeks		Always
n21	Burner working hours		Always

## 4.3 - ADAPTATION TO THE USE OF OTHER GAS

The boilers are produced for the type of gas specifically requested upon ordering.



### DANGER!

The conversion for the operation of the boiler with a type of gas other than that specifically required in the order, must be performed by professionally qualified personnel, in compliance with the standards and regulations in force.

The manufacturer cannot be held liable for any damage resulting from a conversion operation that is incorrect or not performed in compliance with the laws in force and/or with the instructions given.



### ATTENTION!

After performing the conversion for the operation of the boiler with a type of gas (e.g. propane gas) other than that specifically requested when ordering, the appliance will only work with this new type of gas.



### ATTENTION!

Indications for propane gas-fired appliances. Make sure that the gas tank has been deaerated before installing the appliance.

For state-of-the-art deaeration of the tank, contact the LPG supplier or a person qualified in compliance with law.

If the tank has not been professionally deaerated, ignition problems could arise.

In that case, contact the supplier of the LPG tank.

## Gas transformations

### NOTE!

Further details in the section “Technical Information” at the address indicated on page 2.

To convert the boiler from one type of gas to another modify parameter:

PARAMETER par 4.7		
CODE	METANE	PROPANE
A01	0	1



Once the Gt parameter has been modified, it is necessary to perform the automatic calibration (Gas Adaptive Calibration) Chapter 4.3.1

- When the conversion is complete, fill in the information required on the label supplied in the documentation envelope and apply it next to the technical data label of the boiler.

## EXAMPLE OF COMPILATION

	Data - Fecha Date - Datum	08, 09, 05
	Firma - Signature Unterschrift	
- Regolata per	_____	<input type="checkbox"/>
- Réglée pour	G 20	<input type="checkbox"/>
- Adjusted for	G 25	<input type="checkbox"/>
- Reglada para	G 30	<input checked="" type="checkbox"/>
- Eingestellt für	G 31	<input checked="" type="checkbox"/>

ETI 4530C

### NOTE!

Further details in the section “Technical Information” on the boiler page of the [www.unicalag.it](http://www.unicalag.it) website

### 4.3.1 - AUTO-CAL CALIBRATION



**Note:**

The calibration procedure, if carried out correctly and with the use of sanitary water, takes about 9 minutes.

Autocalibration is a function that automatically performs the Iono combustion test at maximum power, at maximum CH power, at 3500 rpm and at minimum power.

Winter mode must be selected and CH or DHW heating request must be OFF.

If chimney sweep function is active, it is stopped when self-calibration function is activated. After starting the self-calibration procedure, the system automatically returns to the main page and the symbols [Water Tap] and [Radiator] flash simultaneously, while temperature and "CAL" alternate every 3 seconds.

It is possible to deactivate the self-calibration before its end using the {MODE} key and placing the boiler in the "OFF" status.

**CAUTION:** Exiting the function before it closes automatically can cause the use of incorrect IONO setting values.



Auto-calibration function must only be used in case of complete replacement of the electronic board and in case of combustion errors memorized on the Eeprom-Key (for details, refer to Par. 4.4 - Board replacement).



To carry out the AUTO-CAL (calibration) go to the menu:

**1 SETTING PARAMETER**

Access by factory code  
(see par. 4.7)

2 - Scroll through the parameters with the {Minus CH} key up to parameter C06 (Autocal)

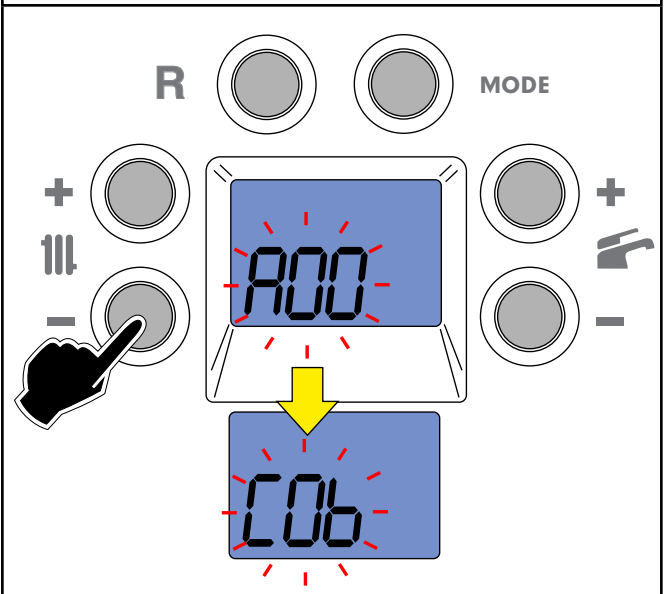

3 - Enter parameter C06 with key {Plus DHW}

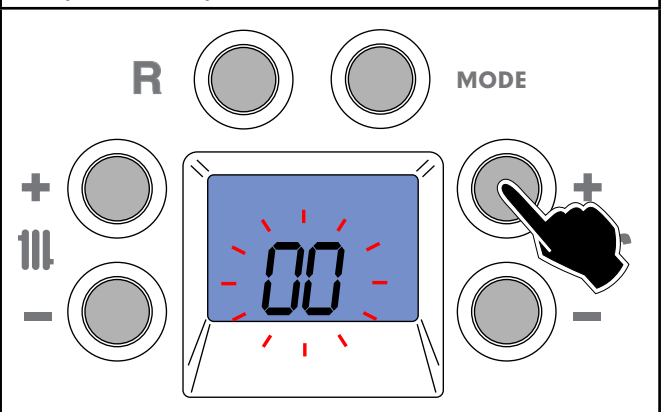

4 - Press {Plus DHW} key and change value from 0 to 1

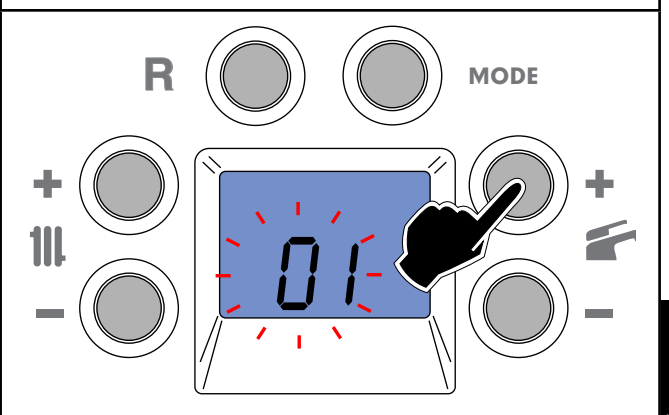

ENGLISH

Maintenance instructions

5 - Activate with {MODE} key

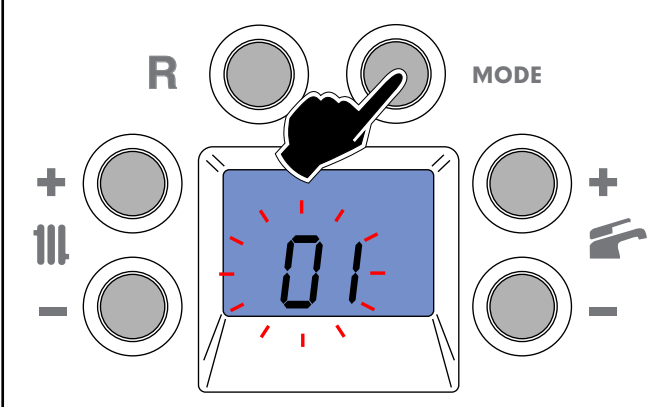

5 - Activate with {MODE} key

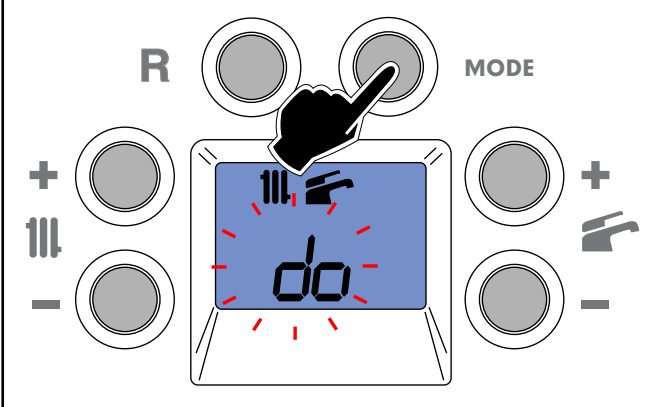

6 - Auto-cal process has started.

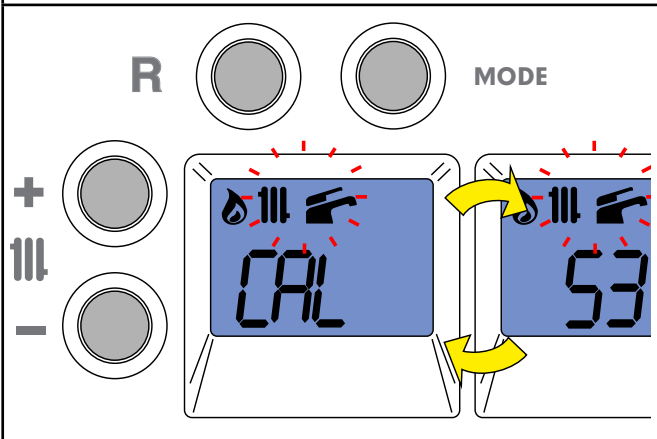

## 4.4 - IMPORTANT NOTES REPLACING COMPONENTS

Before replacing components one must follow the notes of chap. 4 "Inspections and maintenance".

<b>To replace the components:</b>
- <b>MODULATION BOARD</b> (in the event the memory board CANNOT be reused) (*),
Auto-calibration is required (AUTO-CAL (Cap. 4.3.1))

MODULATION BOARD		
A	universal board	
B	memory board (*)	The memory board is programmed by default for METHANE gas operation. In the event of LPG operation the A01 parameter must be edited (Factory parameters), see (Chap. 4.3).
(*) In the event the memory board can be reused, there is no need to reprogram parameters, settings and automatic calibration.		

ENGLISH

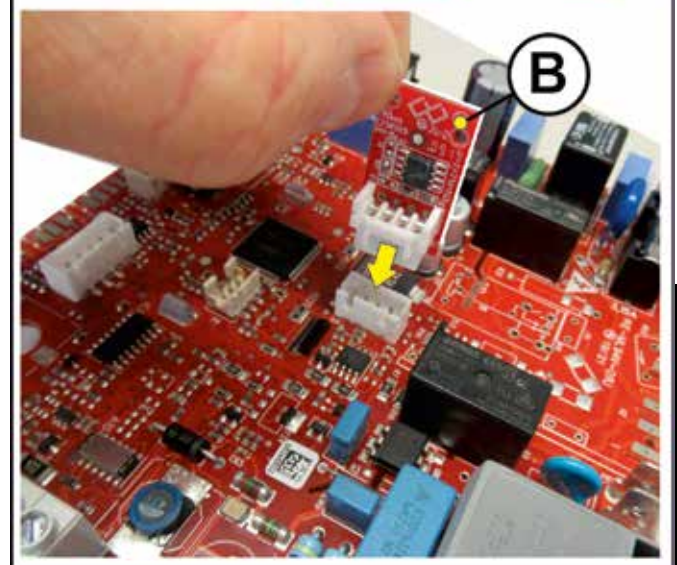
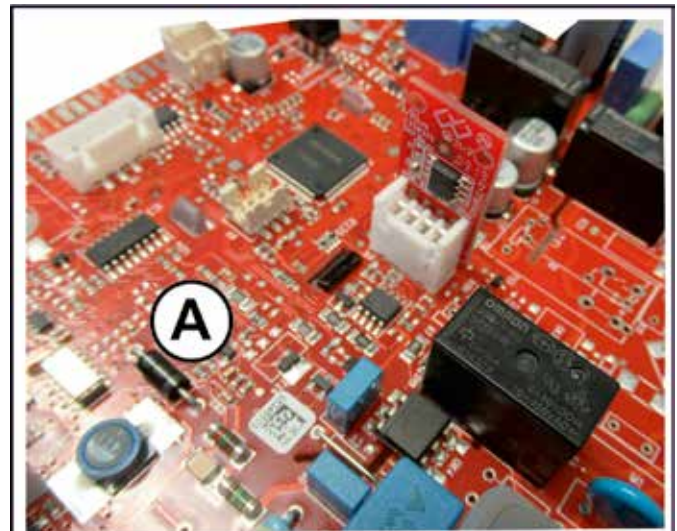

	Act carefully, pay attention to the insertion direction of the memory board.
---	--

Maintenance instructions

# 4.5 - WIRING DIAGRAM

# Practical connection board

COLORI	
BL	BLUE
BR	BROWN
BK	BLACK
G	GREEN
GR	GREY
L BL	LIGHT BLUE
OR	ORANGE
PK	PINK
R	RED
Y	YELLOW
YG	YELLOW/GREEN
WH	WHITE

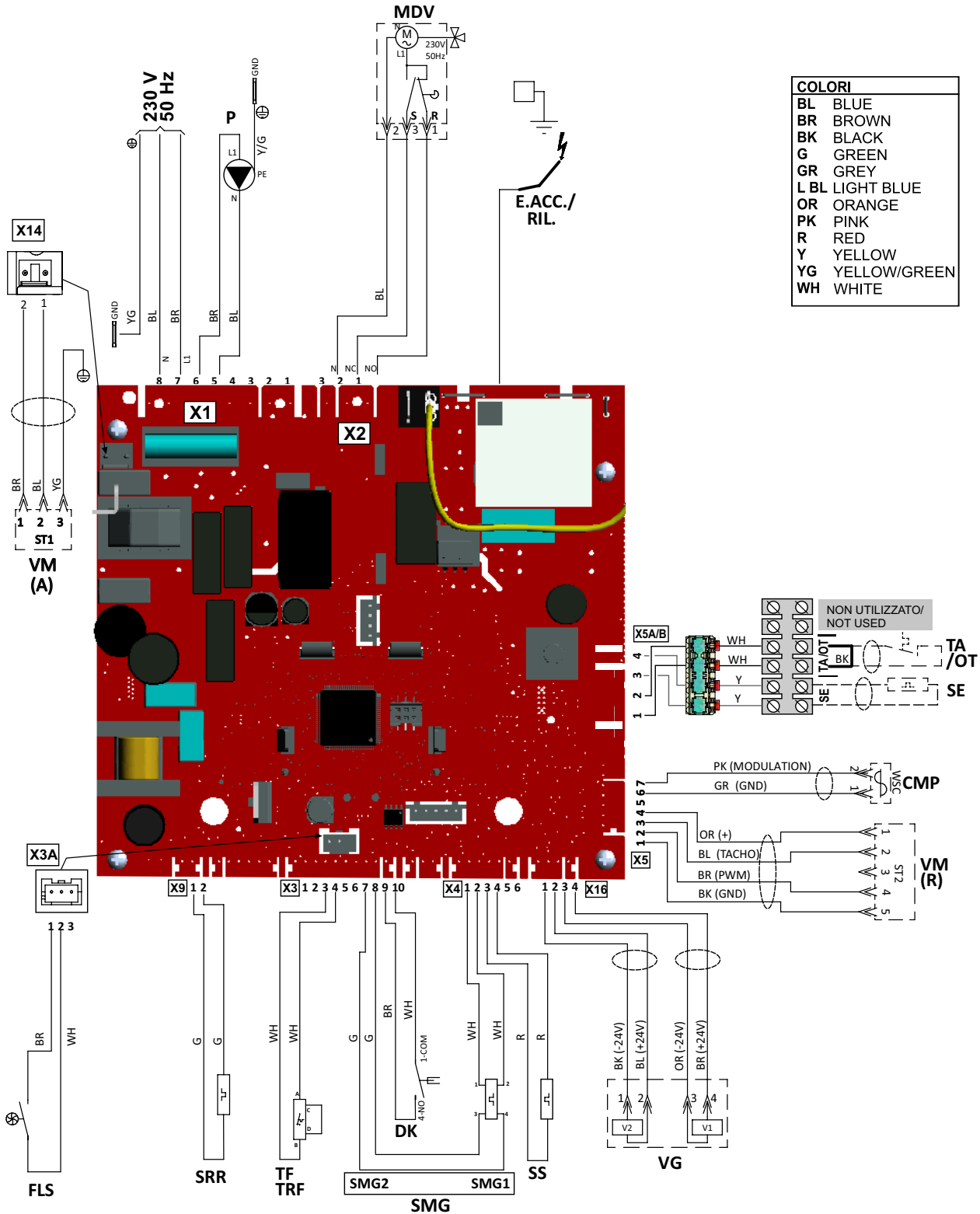

KEY	
X1.....16	Services connectors
CMP	Modulating pump control
DK	Water deficiency safety pressure switch
E. ACC./RIL	Ignition/detection electrode
FLS	Domestic hot water request flow switch
MVD	Diverter valve motor
P	Pump
SMG (1-2)	-I Double sensor temperature: Flow sensor / high limit thermostat

SRR	Return heating sensor
SS	Domestic hot water probe (Pred. for R models)
TF	Limit thermostat
TRF	Thermal fuse
VG	Gas valve
VM	Modulating fan
SE	External probe connection terminals
TA / OT	(Modulating) TA connection terminals



## 4.6 - FAILURE DETECTION

In case of failure the burner is automatically switched off.

PRIORITY	ANOMALY	CODE	TYPE
1	Eeprom fault	E03	Lockout
2	Remote restore attempts exhausted	E52	Lockout
3	VG feedback fault	E26	Lockout
4	Gas valve module insertion sequence fault	E60	Lockout
5	Gas valve not connected	E61	Lockout
6	Generic fault in the gas valve module	E62	Lockout
7	"Ignition not available (ends number of ignition attempts)"	E01	Lockout
8	Limit Thermostat alarm	E06	Lockout
9	$\Delta t$ Temperature difference between flow and return > 35°C	E15	Lockout
10	Tachometric fan signal loss	E05	Lockout
11	Smoke thermostat / smoke overtemperature alarm	E46	Lockout
12	"NTC CH failure / sensor damaged / sensor drift"	E12	Volatile
13	Flue sensor failure H20	E08	Volatile
14	Low water flow	E21	Only showed
15	CH over-heating	E22	Volatile
16	Flue sensor failure	E17	Volatile
17	Hardware board failure caused by an unidentified electrical event	E20	Volatile
18	Return sensor failure	E15	Only showed
19	System frozen	E16	Volatile
21	$\Delta t$ Temperature difference between flow and return > 25°C	E70	Volatile
22	Boiler NTC fault	E28	Volatile
23	DHW NTC failure	E13	Only showed
24	Eeprom damaged on card	98	Only showed
25	Missing or damaged Eeprom stick	97	Only showed
26	Damaged external sensor	E09	Only showed

The Digits shows the error code in blinking mode if volatile lockout, otherwise no blinking if no volatile lockout. Each fault is characterized by a priority level: if different failure are detected at the same time, the code of the most priority one is displayed.

The following failures are recognized:  
Press {Reset} key to reset (unlock) the no volatile alarm (this is in case of alarm root causes already been

## 4.6.1 - COMBUSTION CONTROL ALARMS

Below is a list of the error codes managed by the board relating to the combustion control part.

CODE	DESCRIPTION
<b>E 185</b>	Occur during running state of safety cycle when the flame signal disappears
<b>E 194</b>	Occur during running state of safety cycle close loop control is out of control more than 50 sec
<b>E 195</b>	Excessive change of the gas valve current command in regulation. Switch off the burner for a minimum time of 45s. During this time fan stays ON. If the anomaly E85 appears 6 times in an hour, at the sixth event the no-volatile lockout is set and for a minimum time of 5 minutes the reset from lockout procedure is inhibited and fan stays ON during this time.
<b>E 117</b>	Excessive variation of the current command I <sub>mod</sub> in regulation.
<b>E 188</b>	Flame signal disturbed during ignition phase. The E117 alert is showed only in the alarm history. Only the anomaly code E195 shutdown the boiler with a post-ventilation of 45 seconds at Rpm_Post_Vent speed. Anomaly code E188 occurs during the gas valve opening safety time and is equivalent to a failed ignition attempt.
<b>E 121</b>	Ionization driver hardware check
<b>E 122</b>	Hardware board failure caused by an unidentified electrical event
<b>E 123</b>	Ionization driver hardware check
<b>E 124</b>	Non-consistent Ionization level with combustion control status If the anomaly appears 12 times in an hour, at the twelfth event the no-volatile lockout is set and for a minimum time of 5 minutes the reset from lockout procedure is inhibited and fan stays ON during this time. Unique error code E197 is displayed on HMI interface. After that the switch OFF of the board is required to restore the number of the reset procedure.
<b>E 186</b>	Anomaly chimney obstruction Volatile anomaly reported during pre-ventilation: • up to 60 minute post-ventilation fan speed is maintained before restart ignition cycle

## 4.7 - SET PARAMETER

Press { Minus CH + Minus DHW } key for 4 seconds to access to the parameter setting menu. Press {Plus DHW} key to insert the first password number.

Press {Plus CH} key to confirm.

Press {Plus DHW} key to insert the second password number. Press {Plus CH} key to confirm.

Press {Plus DHW} key to insert the third password number.

Press {Mode} key to confirm the entire password and enter into parameter setting menu.associato, per tornare alla home page basta attendere 1 minuto senza premere nulla.

Press {Minus CH} or {Plus CH} key to select the parameter.

Press {Minus DHW} or {Plus DHW} key to change the value of the parameter. Press {Mode} key to confirm new value.

Press {Plus CH} to return to parameters menu and then press {Mode} to return to the home page.

As an alternative, after having chosen the parameter and the associated value, to return to the home page just wait 1 minute without pressing anything.

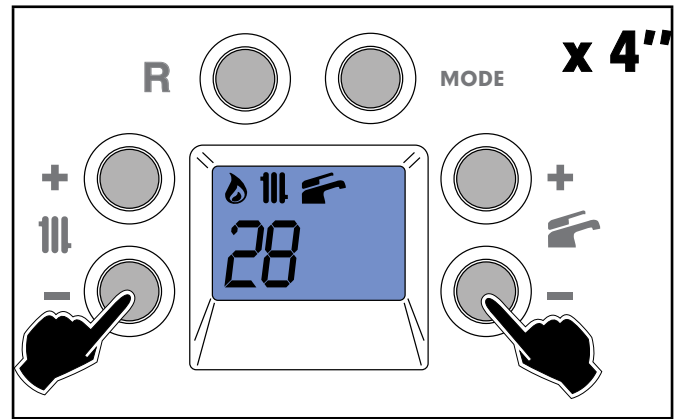

ENGLISH

COD.	TSP	DESCRIPTION	MIN	MAX	DEFAULT	STEP	UM	ACCESS. LEVEL
P03	5	Post-circulation time	0	99	30	1	sec	1
P04	6	Post-ventilation time	0	99	20	1	sec	2
P05	8	Anti-cycle time	0	255	3	1	min	1
P08	11	K factor for climatic compensation	0,2	3,0	1	0,1		1
P09	12	Tipo di controllo della pressione dell'acqua	0 = Pressure switch		0	1		1
A00	13	Hydraulic configuration	0 = mono-thermal 1 = storage tank 2 = only heating		0	1		2
A01	14	Gas type	0=met 1=GPL		0	1		1
A02	15	Heating circuit type	1 = high temp. 2 = low temperature 3 = full range		3	1		1
A03	16	DHW pre-heating function	0 = disabled 1 = enabled		0	1		1
A04	-	Min rpm				50	giri/min	1
A05	-	Max CH rpm						
A06	-	Max rpm						
A08	25	Delta T exchanger	10	30	17	1	°C	1
A09	26	Storage tank regulation Setpoint	50	80	80	1	°C	1
A10	27	Burner ignition hysteresis	-10	10	-3	1	°C	1
A11	28	Burner shutdown hysteresis	-10	10	3	1	°C	1
A12	29	DWH input	0 = flow switch 1 = flow meter		0	1		2
A14	30	CH power ramp	0	99	10	1	min	1

Maintenance instructions

COD.	TSP	DESCRIPTION	MIN	MAX	DEFAULT	STEP	UM	ACCESS. LEVEL
A16	31	Pump speed reduction time during 3-way switching	0=n.u. 1 ÷ 10		6	1		2
b00	32	Proportional band CH	1	40	15	1		2
b01	33	Ti CH	0	60	25	1		2
b02	34	Tcd CH	0	80	5	1		2
b03	35	Td CH	0	100	0	1		2
b04	36	Proportional band DHW	1	40	15	1		2
b05	37	Ti ACS	0	60	20	1		2
b06	38	Tcd ACS	0	80	5	1		2
b07	39	Td ACS	0	100	25	1		2
A17	48	Control type DHW	0=DHW sensor 1=CH sensor		0	1		2
A18	49	Type Control of tank	0=Tank with probe 1= thermostated tank		0	1		1
A21	-	Thermostat Type Selection	0=ON/OFF thermostat 1= OT+		0	1		1
A23	52	Pump management	0=ON/OFF 1=PWM reduced to min PWM		1	1		2
A24	53	PWM pump management during CH (if A23=1)	29=OFF 30÷100% 101=AUTO		101	1	%	2
A25	54	Delta temperature during CH (if A23=1)	10	35	25	1	°C	1
A26	55	Delta temperature during DHW (if A23=1)	10	35	25	1	°C	2
A27	56	PWM pump refresh time during CH (if A23=1)	1	10	10	1	min	1
A28	57	PWM update time pump during DHW (if A23=1)	1	10	10	1	min	2
A29	58	PWM pump management during DHW (if A23=1)			100	1	%	2
A30	59	Min PWM pump speed during CH	20	100	40	1	%	2
A31	60	Min PWM pump speed during DHW	20	100	40	1	%	2
A32	61	Max temp offset during AUTO mode to switch at max speed	0	50	10	1	°C	2
A33	62	Antilegionella frequency	0	30	7	1	DAY	1
A34	63	Antilegionella Temperature	65	85	70	1	°C	1
A35	64	Antilegionella Temperature time	0	30	1	1	Min	1

COD.	TSP	DESCRIPTION	MIN	MAX	DEFAULT	STEP	UM	ACCESS. LEVEL
A36	65	DHW setpoint negative hysteresis (->ON)	-10	10	-3	1	°C	1
A37	66	DHW setpoint positive hysteresis (->OFF)	-10	10	3	1	°C	1
A38	67	Post-circulation time in DHW	0	99	60	1	Sec	1
A40	69	DHW Off control DHW: 0 = Variable - 1 = fix			1	1		1
A41	70	DHW request delay	0	20	1	1	Sec	1
A42	71	CH start delay	0	60	1	1	Sec	1
A43	72	CH setpoint negative hysteresis (->ON)	-10	10	-4	1	°C	1
A44	73	CH setpoint positive hysteresis (->OFF)	-10	10	4	1	°C	1
A45	74	Automatic purging (boiler venting)			1	1		1
A46	75	DHW pre-heating minimum offset	0	15	3	1	°C	1
A49	81	Reset parameters to factory value (4)"	39 = reset value other = no action		0	1		2
A50	82	Max CH setpoint limit	high=50 low=25 Full range=25	high=80 low=55 Full range=85	80 55 85	1	°C	1
A52	84	Exhaust probe enable (7)	0=deactivate 1=activate		0	1		1
A54	86	Activation periodical service warning (5)	0=disattiva 1=avviso 6 settimane prima della scadenza tempo servizio		0	1		2
A55	87	Time of weeks from next periodic service notice (6)	0	208	52	1	settim	1
C00	-	Fan monitoring	0=deactivate 1=activate		0	1		2
C01	-	Aging test	0=deactivate 1=activate		0	1		2
C03	90	Boiler Type	1=1824kW 2=2024kW 3=2424Kw		1	1		2
C04	-	Restore Combustion Offset	0	1		1		2
C05	-	Reset combustion offset	0	1		1		2
C06	-	Auto-cal	0=deactivate 1=activate		0	1		2
C07	-	Sweeper function	0 = off 1 = minim power 2 = maxim power 3 = maxim power CH		0	1		2
C08	-	Co2 reg min	-8	+8	0	1		2
C09	-	Co2 reg max	-8	+8	0	1		2
C10	-	Co2 agg cap	-8	+8	0	1		2

ACC. LIV. (1) Installer level 1 access = xx, OEM Level 2 access = xx





# Unical®



[www.unical.eu](http://www.unical.eu)

ORIGINAL INSTRUCTION - 00339883EN - 1<sup>st</sup> ed. 01/25

**Unical** AG S.p.A. 46033 casteldario - mantova - italia - tel. +39 0376 57001 - fax +39 0376 660556  
info@unical-ag.com - export@unical-ag.com - www.unical.eu

Unical declines every responsibility for the possible inaccuracies if owed to errors of transcript or press.  
Also reserves the right to bring those changes that it will hold necessary to its own products or profits, without jeopardizing its essential characteristics.